



Installation Instructions

for

Air / Oil Separator Kits

AIRWOLF FILTER, CORP

12801 Hwy 75 North

Okmulgee, Oklahoma 74447-1337 U.S.A.

USA-1-(918) 561-8696 / (918) 561-8695 Fax

<http://www.airwolf.com> / Email: support@airwolf.com

List of Effective Pages

Page Number	Revision	Revision Date
Cover	D	May 12, 2020
1	D	May 12, 2020
2	D	May 12, 2020
3	D	May 12, 2020
4	D	May 12, 2020
5	D	May 12, 2020
6	D	May 12, 2020
7	D	May 12, 2020
8	D	May 12, 2020
9	D	May 12, 2020
10	D	May 12, 2020
11	D	May 12, 2020
12	D	May 12, 2020
13	D	May 12, 2020
14	D	May 12, 2020
15	D	May 12, 2020
16	D	May 12, 2020
17	D	May 12, 2020
18	D	May 12, 2020
19	D	May 12, 2020
20	D	May 12, 2020
21	D	May 12, 2020
22	D	May 12, 2020
23	D	May 12, 2020
24	D	May 12, 2020
25	D	May 12, 2020
26	D	May 12, 2020
27	D	May 12, 2020
28	D	May 12, 2020
29	D	May 12, 2020
30	D	May 12, 2020

Page Number	Revision	Revision Date
31	D	May 12, 2020
32	D	May 12, 2020
33	D	May 12, 2020
34	D	May 12, 2020
35	D	May 12, 2020
36	D	May 12, 2020
37	D	May 12, 2020
38	D	May 12, 2020

Approved By: Blair Hilt
 Quality Manger

Date: May 12, 2020

Approved By: James A. Grigg Manager, Ft Worth ACO
 FAA ACO

Date: June 6, 2020

Table of Contents

<u>Section</u>	<u>Page</u>
List of Effective Pages.....	1
Table of Contents.....	2
Data Pertinent to all Installations	3
Installation Instructions.....	4
Schematic of Typical Installations with Vacuum Pumps	5
Schematic of Typical Installations without Vacuum Pumps.....	6
Schematic of Typical Minisep Installations with Wet Vacuum Pumps.....	7
Schematic of Typical Installations without Vacuum Pump(Engine Breather only)	8
Schematic of Typical Installations on Engine Baffle mounted Airseps (shown on Cessna 182) (Fig 1).....	9
Schematic of Typical Installations on Engine Baffle mounted Airseps (shown on Cessna 182) (Fig 2).....	10
Installation Instructions (Engine Baffle Mounted Airseps)	11
Typical Installations on Engine Baffle mounted Airseps (shown on Cirrus SR22)	12
Schematic of Typical Installations on Engine Mount mounted Airseps.....	13
Installation Instructions (Engine Mount Mounted Airseps)	14
Typical Installations on Engine Mount mounted Airseps (shown on Comanche PA-30)	15
Schematic of Typical Installations of Firewall mounted Airseps (shown on Cessna U206)	16
Installation Instructions (Firewall mounted Airseps)	17
Typical Installations of (Firewall mounted Airseps) (shown on Beech A36 Bonaza).....	18
Typical Installations of Engine Baffle mounted Airseps (shown on Globe Swift)	19
AirSep Assemblies (W-3000 thru W-3011)	20
AirSep Assemblies (W-3012 thru W-3019)	21
AirSep Assemblies (W-3020 thru W-3032)	22
AirSep Assemblies (W-3034 thru W-4100-C)	23
Oil Return Method List Selection Guide.....	24
Illustrations of Oil Return methods Air Syphons (W-2008 Thru W-2156-1)	25-29
Illustration of Parts AirSep Figure 1, 2 & 3.....	30-32
Parts List of Components for Installation on Aircraft (1 thru 58)	33-34
Typical AirSep Assembly Part Number List and Description.....	35
Illustration of Parts MiniSep Figure 4,	36
Typical MiniSep parts required to install on Aircraft.....	37
Instructions for Continued Airworthiness (ICA)	38



READ THIS BEFORE INSTALLING AIR/OIL SEPARATOR DATA PERTINENT TO ALL INSTALLATIONS

1. REVIEW ALL INSTALLATION DATA AND WRITTEN MATERIAL BEFORE BEGINNING

2. There is **no reason** to open the Airwolf Air/Oil Separator before it is installed on the aircraft. It has been carefully assembled and tested at the factory. If you find it necessary to relock the top or bottom of the airsep for your installation, loosen the 5/16" locknut on the top of the airsep, adjust the inlets or outlets to the proper angles and retighten the top of the Airsep to 25 in/lbs. \pm 5. In the event of a dry vacuum pump failure, the Air/Oil Separator and all related fittings and hoses should be cleaned, inspected, or replaced as necessary
3. **Do not** over tighten the large band clamp that holds the Air/Oil Sep to the universal mount. This can distort the shape of the can, causing oil to seep out at the seam. The Air/Oil Sep clamp is wrapped with a piece of rubber material for protection
4. It is **EXTREMELY** important that the 1/4" & 5/16" oil return lines and lines from the vacuum pump have good gravity flow with **NO** low spots.
5. The installed Air/Oil Sep weighs an average of 24 oz. Please subtract for any items removed from the aircraft
6. The placement of the 1-3/4" outlet duct is **VERY IMPORTANT** to the proper operation to the Airwolf Air/Oil Separator. The rules for placement are follows:
 - A. The velocity of the air passing the end of the duct, **cannot** exceed the velocity of the air exiting the end of the tube, or a syphon effect will occur
 - B. The Air/Oil Sep is pressurized by the air discharged from the vacuum pump. This blows the fumes out through the bottom of the Air/Oil Sep, therefore there is **no need** for high velocity slipstream air to siphon fumes out of the Air/Oil Sep. If you fail to heed this advice and allow the 1-3/4" duct to stick into the high velocity slip stream, the air/oil stream exiting the crankcase breather tube will not have proper time to coalesce inside the Air/Oil Sep and this oil laden air **will** discharge onto the belly of the aircraft, creating the same problem that the Air/Oil Sep was thoroughly designed to stop. ***Trust us, we know what we're talking about.***
 - C. On aircraft with cowl flaps, the 1-3/4" outlet ducting should be approximately 6" above the cowl flap area, and 3" to 4" on either side of the cowl flap centerline
 - D. On **ALL** installations, it normally takes 2-3 flights and 4-5 hrs of aircraft operation to properly adjust the position of the 1-3/4" outlet ducting to achieve perfection. ***BE PATIENT!!!*** Take your time and you will see the clean results of your effort.

The Airwolf Air/Oil Separator is up to 94% effective in separating the oil from the blow-by gasses and when properly tuned, will keep the bottom of the aircraft very clean.

Thank you for taking the time to read this.

Airwolf Filter Corp.

This STC provides for the installation of the Airwolf AirSep™ and Airwolf MiniSep™ kit.

The AirSep™ assy is 4" Dia. X 6" Tall and has two inlets at the top. One inlet connects to the engine breather line, and one inlet connects to a vacuum pump [wet or dry] or an alternate source of hot air such as upper cylinder deck air

The MiniSep™ assy is 3" Dia. X 4" Tall and has a single inlet at the top which connects either to an engine breather line, or to the exhaust of a wet vacuum pump

For both AirSep™ and MiniSep™ installations:

- 1) Select the best installation location for your application [Option 1, 2, or 3 below] and follow the instructions for that installation. (See typical installations Pages 5-19)

This installation may be performed using one of the three different options for mounting the AirSep™ or MiniSep™ assy.

- 1) Engine Baffle [EB] [See Pages 9 - 12]
- 2) Engine Mount [EM] [See Pages 13 – 15]
- 3) Firewall Mount [FW] [See Pages 16 – 19]

- 2) Select the appropriate AirSep or MiniSep assy part number from Pages 20-24 by matching the existing size of the engine breather line [normally 5/8, 3/4", 1" or 1-1/4" O.D.] to the same size inlet on the AirSep or MiniSep assy.

For AirSeps: Decide which 1/2" or 5/8" fitting "clock angle" on the AirSep assy provides the best hose routing to the vacuum pump or engine baffle through hole, whichever is chosen for the source of hot air.

- 3) Select the appropriate oil return method from Pages 25 - 30 to return the recovered oil to the engine sump.

Note: The drain on the AirSep or MiniSep can be relocked to give the shortest, simplest route to the engine by loosening the top nut. Simply twist the bottom of the AirSep or Mini Sep to get the correct clocking and then retighten the top nut to 25 in/lbs. \pm 5

- 4) Simply fill out a FAA Form 337 by checking Option "EB", "EM", or "FW", etc. On the back of Form 337, detail all parts used in the particular aircraft installation (See pages 30-37)(*Parts List*). Note hose type, size and lengths used for each hose (for future easy replacement) and any additional information that may be pertinent to your installation.
- 5) Attach a copy of the ICA (See page 38) and Form 337 to logbook or file in engine maintenance records.

NOTE: If you develop any useful installation hints or practices that may be useful, please contact: Airwolf Filter, Corp 12801 Hwy 75 North, Okmulgee, OK 74447. (918) 561-8696 , (918) 561-8696 or support@airwolf.com. We are always interested in improving our products and services to our customers

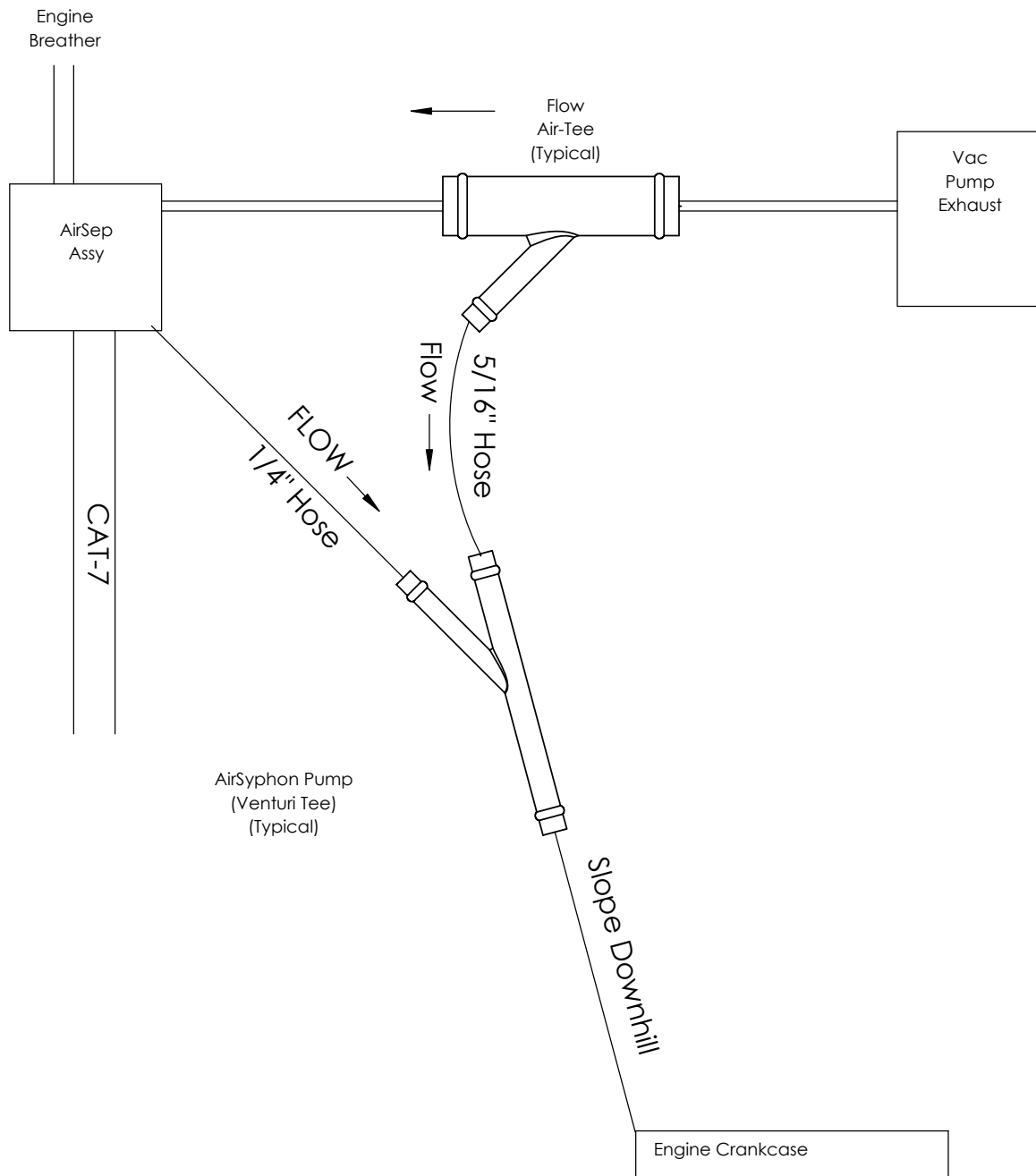

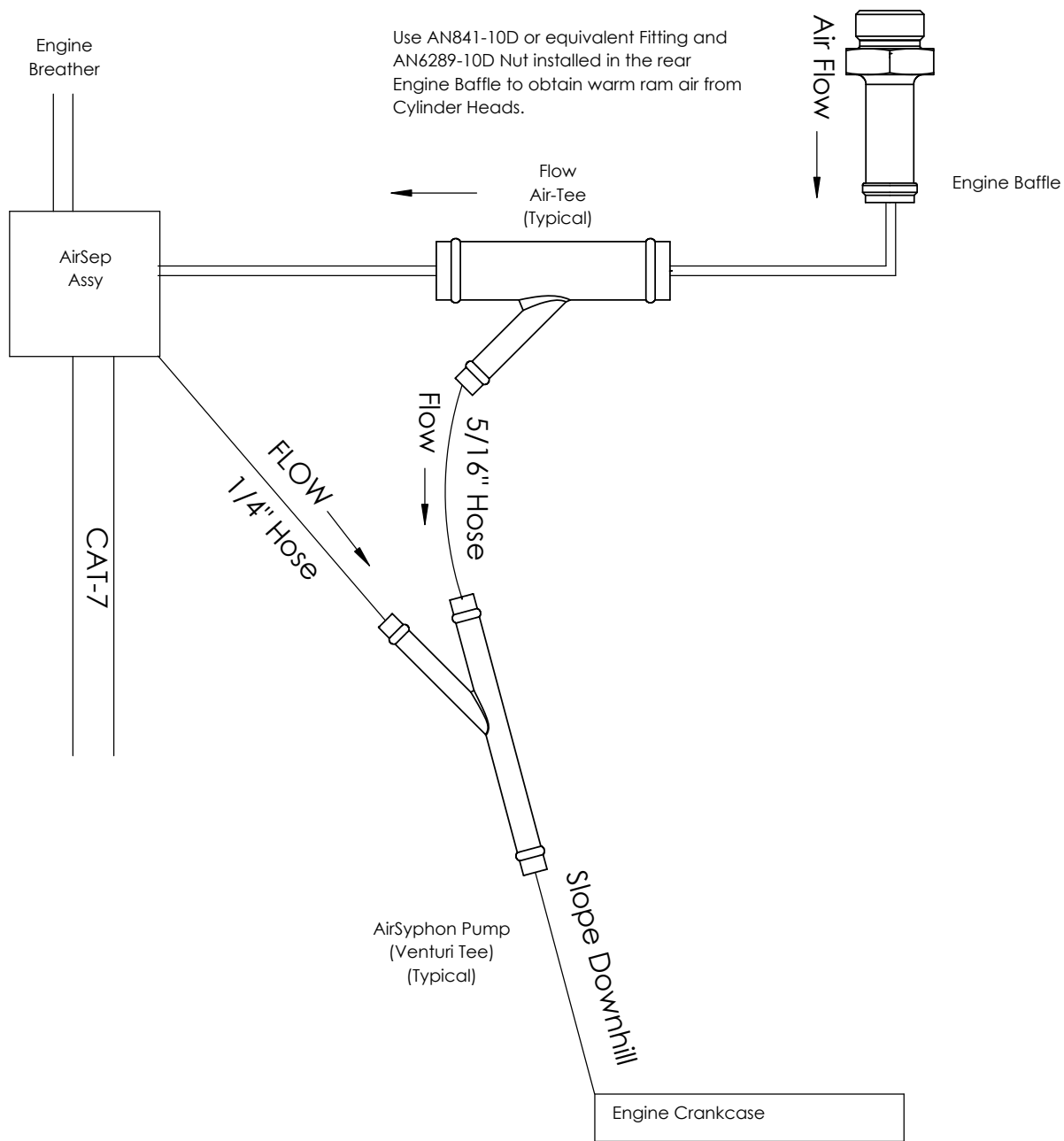

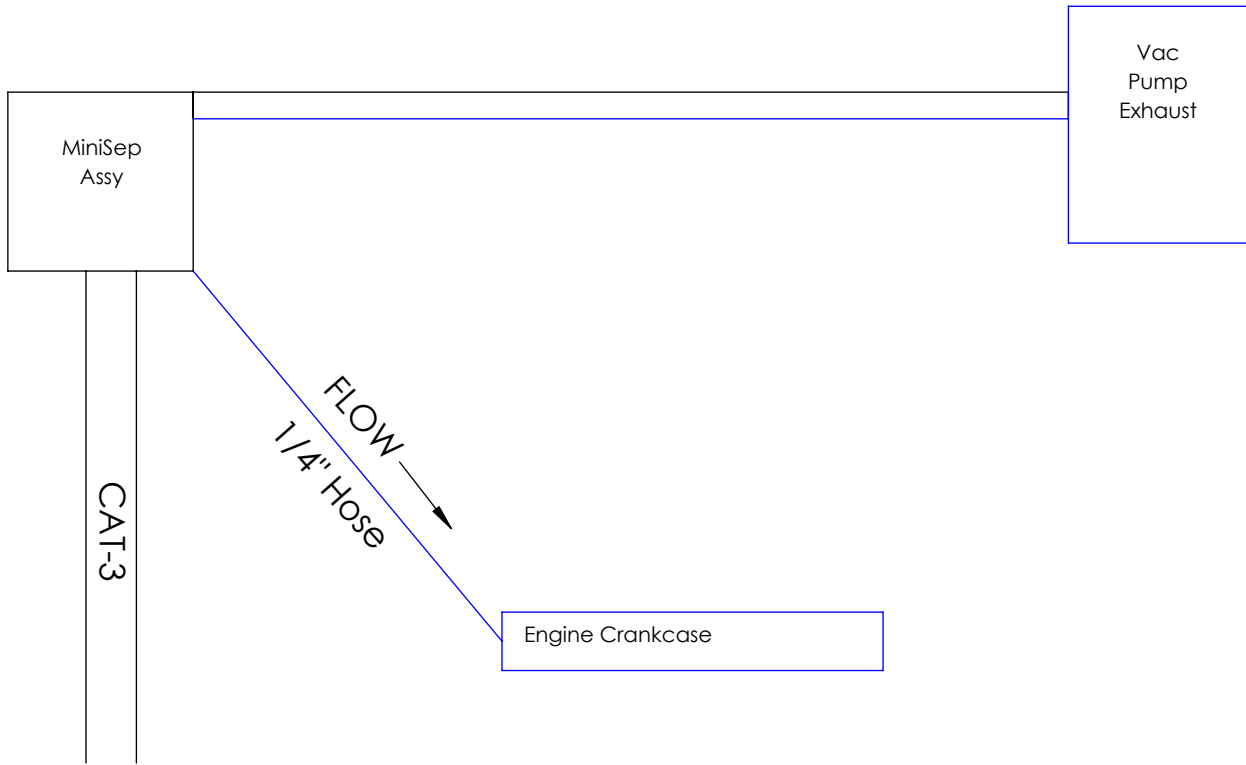

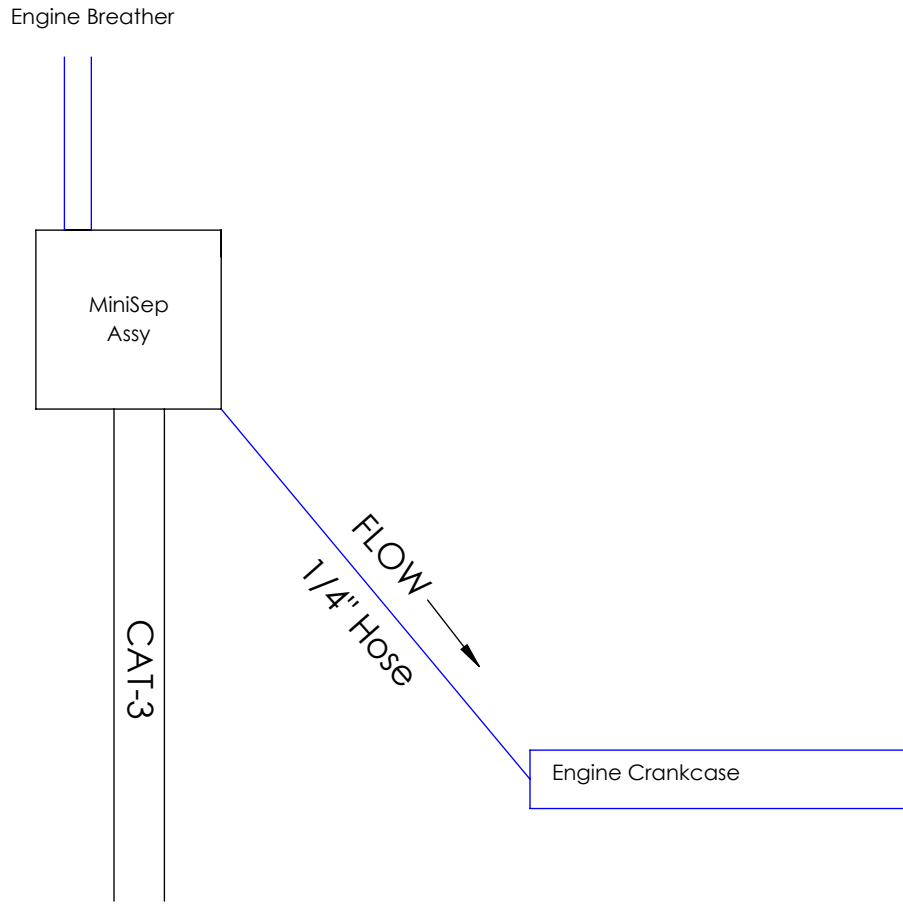

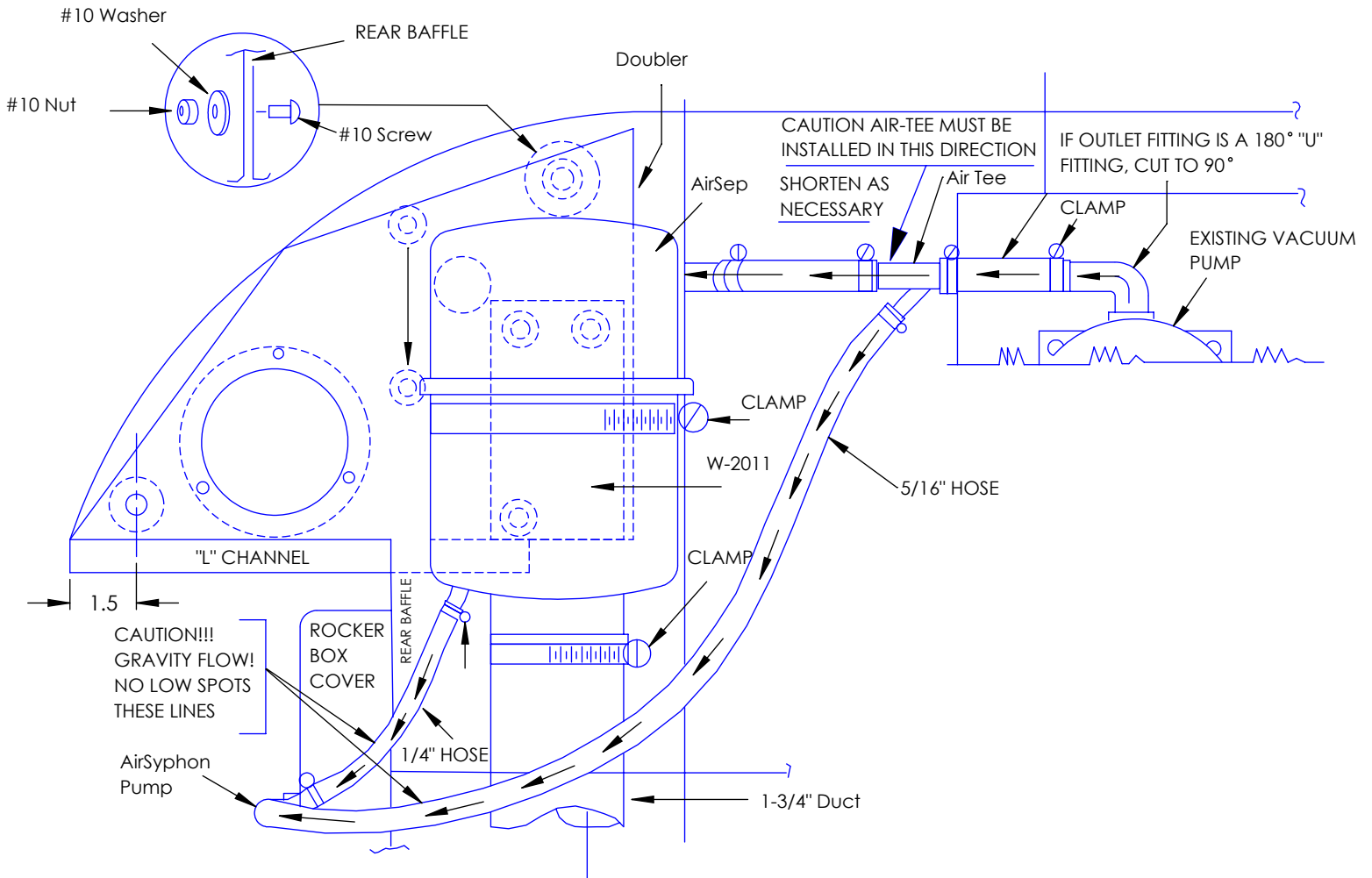

FIGURE 1

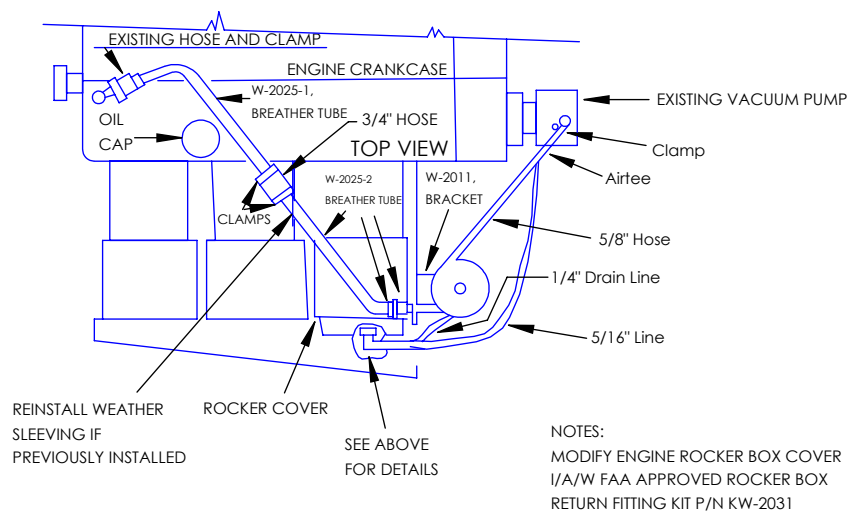
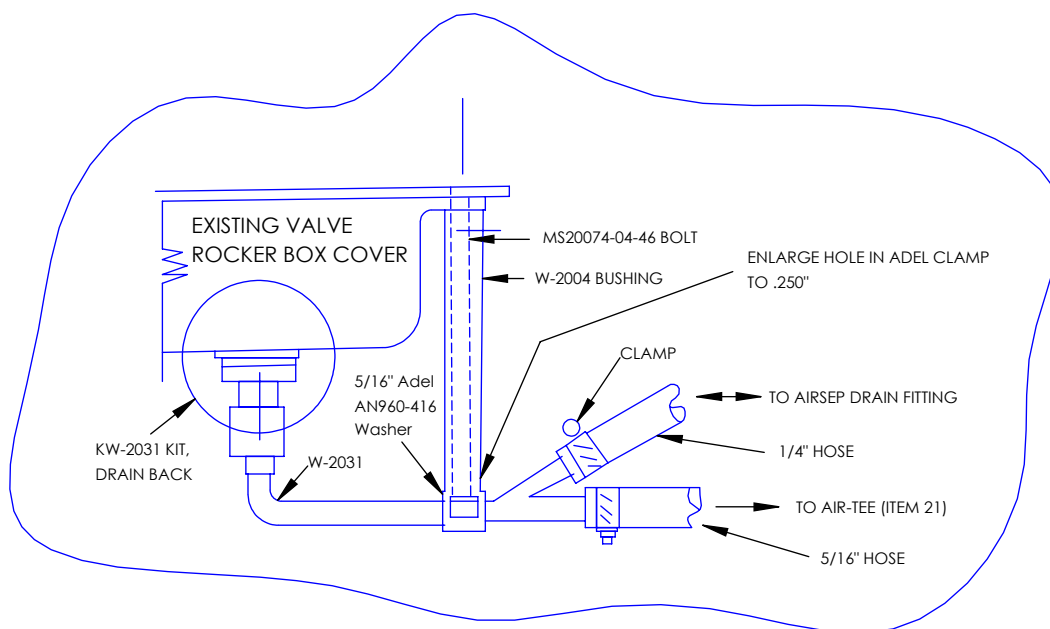

FIGURE 2

Applicability: Engine Baffle Mounted Airsep

*Note A: Some hoses or wires may have to be rerouted so the air/oil separator will fit into position.
Reference and material per AC 43.13-1B & 2A*

WARNING: ALL HOSES SHALL BE LOCATED AT LEAST 4.0" FROM ANY HEAT SOURCE LIKELY TO CAUSE VAPORIZATION OF THE OIL

1. Gain access to engine compartment.
2. Using the W-2011 bracket as a template, center the bracket on the LH or RH rear engine baffle and drill four 3/16" holes.
3. Mount the W-2011 bracket on the engine baffle, using the W-2150 doubler positioned on the fwd side of the engine baffle and loosely hold in place with 4 ea #10 screws, washers and locknuts.
4. Slide the 4-1/2" clamp between the W-2011 bracket and the engine baffle to be used to hold the AirSep.
5. Tighten the four #10 screws installed in step #3 at this time.
6. Mount AirSep to W-2011 bracket and tighten the 4-1/2" clamp.

NOTE: Bottom drain line of the AirSep must be positioned so that it is above the level of the entrance to the engine. Oil must be able to drain downhill.

NOTE: If the bottom drain is not "clocked" correctly for the aircraft, loosen the top 5/16-24 Nut. Then, holding the can top, twist the can bottom to get the correct orientation to provide the simplest flow to the engine. Then retighten the nut to no more than 25 in/lbs. \pm 5.

7. Using a piece of MIL6000 hose, connect the inlet of AirSep to existing engine breather line and secure with QS100 clamps.
- 8a. If no vacuum pump installed on the aircraft, drill a 5/8" hole into the engine baffle, Install an AN841-10D or equivalent fitting and AN6289-10D Nut. Run a piece of 5/8" MIL6000 hose from the fitting in the baffle to the Air-Tee, and from the Air-Tee to the 5/8" inlet on the AirSep to gain hot ram air from top of cyls.

NOTE: Make sure the word "Flow" on the Air-Tee is pointing towards the AirSep.

- 8b. If a vacuum pump is installed on the aircraft, use a piece of MIL6000 hose to connect the 5/8" exhaust fitting on the vacuum pump to the Air-Tee, and from the Air-Tee to the 5/8" inlet on the AirSep to gain hot vacuum pump exhaust
9. Determine the method of returning the recovered oil in the AirSep, to the engine. Connect an Air Syphon pump to the engine, I/A/W the schematic shown on page 9.
10. Connect the 5/16" branch of the Air Syphon Pump to the 5/16" branch of the Air-Tee.
11. Connect the 1/4" branch of the Air Syphon Pump to the 1/4" drain on the AirSep
12. Connect a length of CAT-7 hose to the bottom of the AirSep and secure with a 1-3/4" clamp.
13. Secure the CAT-7 hose to an engine mount, firewall or structure using a -30 Adel Clamp.

NOTE: Do not allow the CAT-7 hose to extend out the bottom of the engine cowl. If you fail to heed this advice and allow the 1-3/4" duct to stick into the high velocity slip stream, the air/oil stream exiting the crankcase breather tube will not have proper time to coalesce inside the Air/Oil Sep and this oil laden air will discharge onto the belly of the aircraft, creating the same problem that the Air/Oil Sep was thoroughly designed to stop.

14. Determine weight & balance, initiate Form 337, and update the equipment list

Applicability: Typical Engine Baffle Mounted Airsep Shown on Cirrus SR22

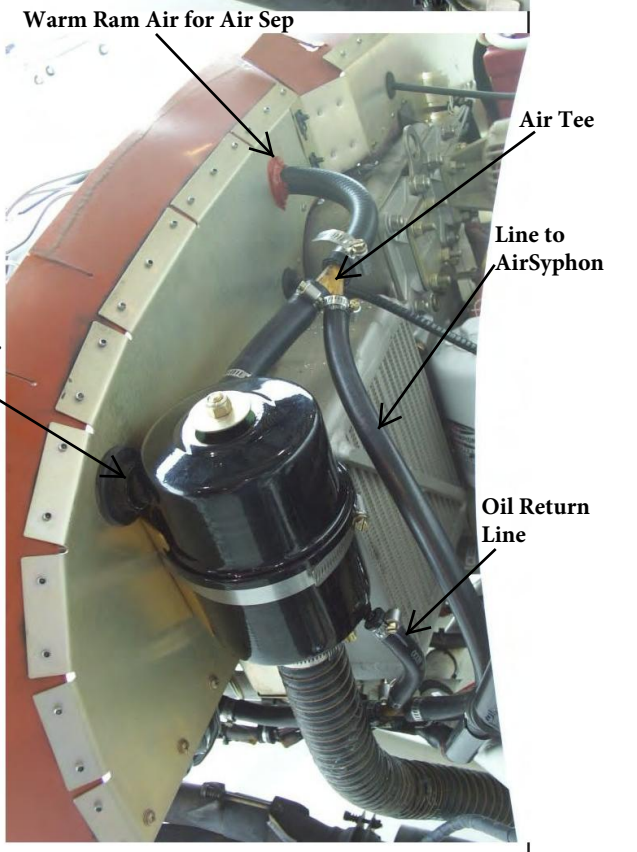
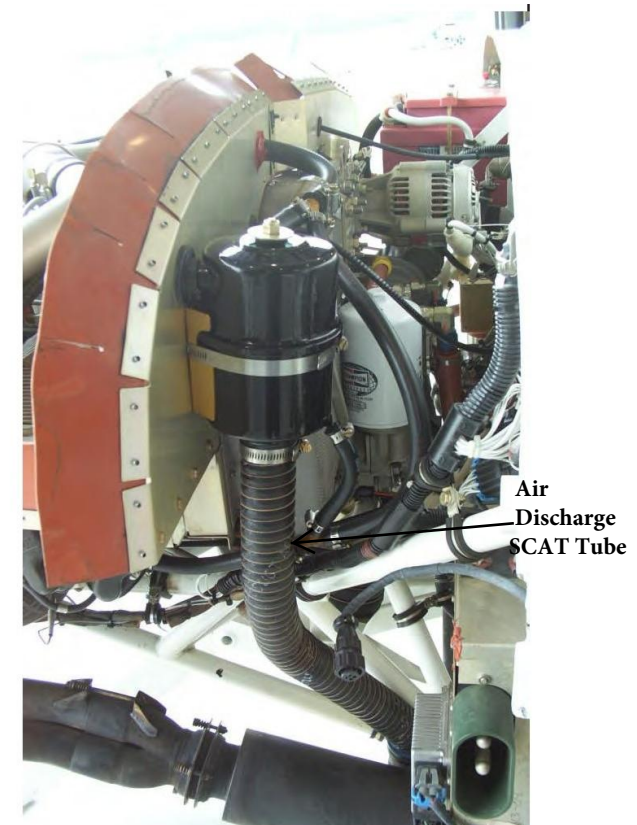
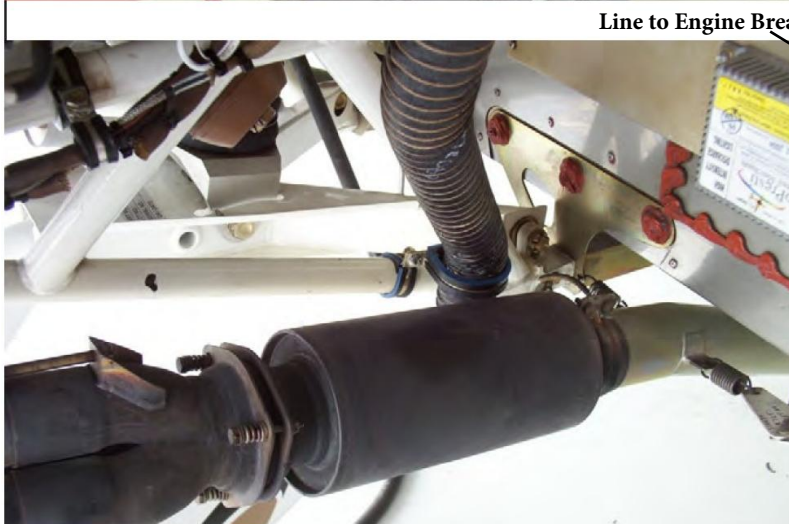
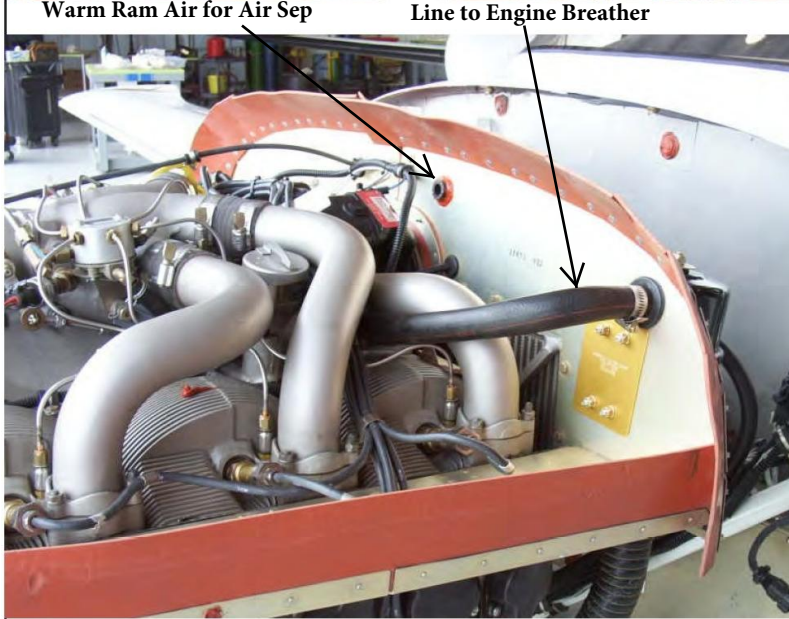
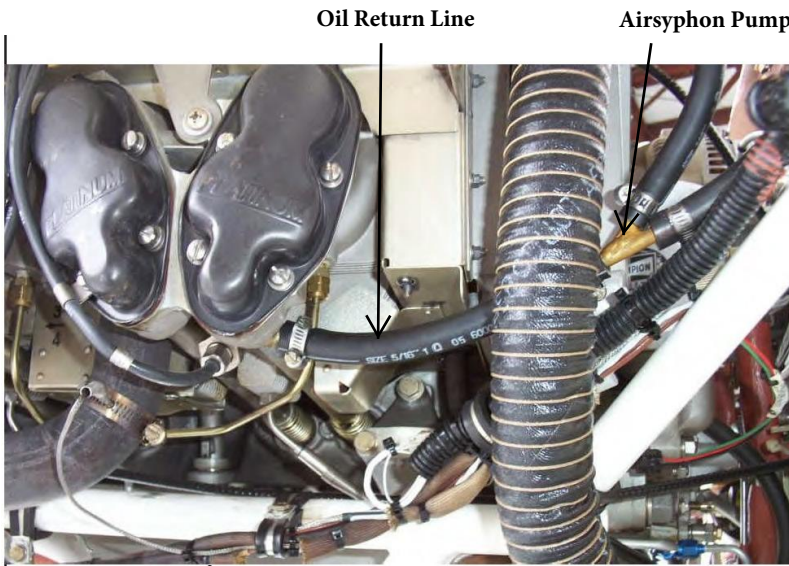

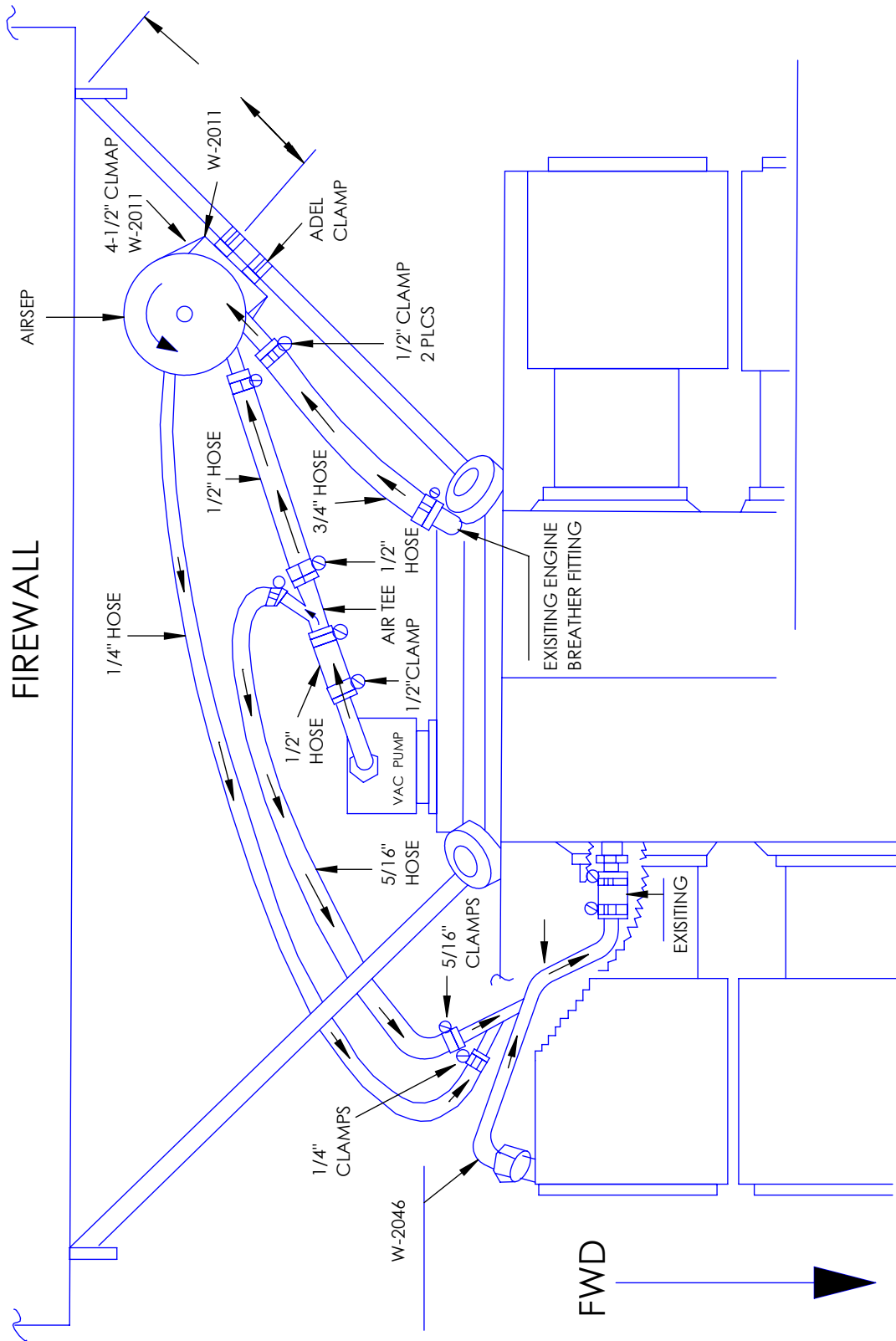

Applicability: Typical Engine Mount Mounted Airsep

*Note A: Some hoses or wires may have to be rerouted so the air/oil separator will fit into position.
Reference and material per AC 43.13-1B & 2A.*

WARNING: ALL HOSES SHALL BE LOCATED AT LEAST 4.0" FROM ANY HEAT SOURCE LIKELY TO CAUSE VAPORIZATION OF THE OIL.

1. Gain access to engine compartment.
2. Secure a mounting bracket, to the engine mount with appropriate Adel clamps and standard hardware.
3. Attach the W-2011 bracket on the previously installed mounting bracket with 4 ea #10 screws, washers and locknuts.
4. Slide the 4-1/2" clamp between the W-2011 bracket and the mounting bracket to be used to hold the AirSep.
5. Tighten the four #10 screws installed in step #3 at this time.
6. Mount AirSep to W-2011 bracket and tighten the 4-1/2" clamp.

NOTE: Bottom drain line of the AirSep must be positioned so that it is above the level of the entrance to the engine. Oil must be able to drain downhill.

NOTE: If the bottom drain is not "clocked" correctly for the aircraft, loosen the top 5/16-24 Nut. Then, holding the can top, twist the can bottom to get the correct orientation to provide the simplest flow to the engine. Then retighten the nut to no more than 25 in/lbs. \pm 5.

7. Using a piece of MIL6000 hose, connect the inlet of AirSep to existing engine breather line and secure with QS100 clamps.
- 8a. If no vacuum pump installed on the aircraft, drill a 5/8" hole into the engine baffle, Install an AN841-10D or equivalent fitting and AN6289-10D Nut. Run a piece of 5/8" MIL6000 hose from the fitting in the baffle to the Air-Tee, and from the Air-Tee to the 5/8" inlet on the AirSep to gain hot ram air from top of cyls.

NOTE: Make sure the word "Flow" on the Air-Tee is pointing towards the AirSep

- 8b. If a vacuum pump is installed on the aircraft, use a piece of MIL6000 hose to connect the 5/8" exhaust fitting on the vacuum pump to the Air-Tee, and from the Air-Tee to the 5/8" inlet on the AirSep to gain hot vacuum pump exhaust.
9. Determine the method of returning the recovered oil in the AirSep, to the engine. Connect an Air Syphon pump to the engine I/A/W the schematic shown on page 9.
10. Connect the 5/16" branch of the Air Syphon Pump to the 5/16" branch of the Air-Tee.
11. Connect the 1/4" branch of the Air Syphon Pump to the 1/4" drain on the AirSep.
12. Connect a length of CAT-7 hose to the bottom of the AirSep and secure with a 1-3/4" clamp.
13. Secure the CAT-7 hose to an engine mount, firewall or structure using a -30 Adel Clamp.

NOTE: Do not allow the CAT-7 hose to extend out the bottom of the engine cowl. If you fail to heed this advice and allow the 1-3/4" duct to stick into the high velocity slip stream, the air/oil stream exiting the crankcase breather tube will not have proper time to coalesce inside the Air/Oil Sep and this oil laden air will discharge onto the belly of the aircraft, creating the same problem that the Air/Oil Sep was thoroughly designed to stop

14. Determine weight & balance, initiate Form 337, and update the equipment list.

Applicability: Typical Engine Mount Mounted Airsep shown on a PA-30 Comanche.



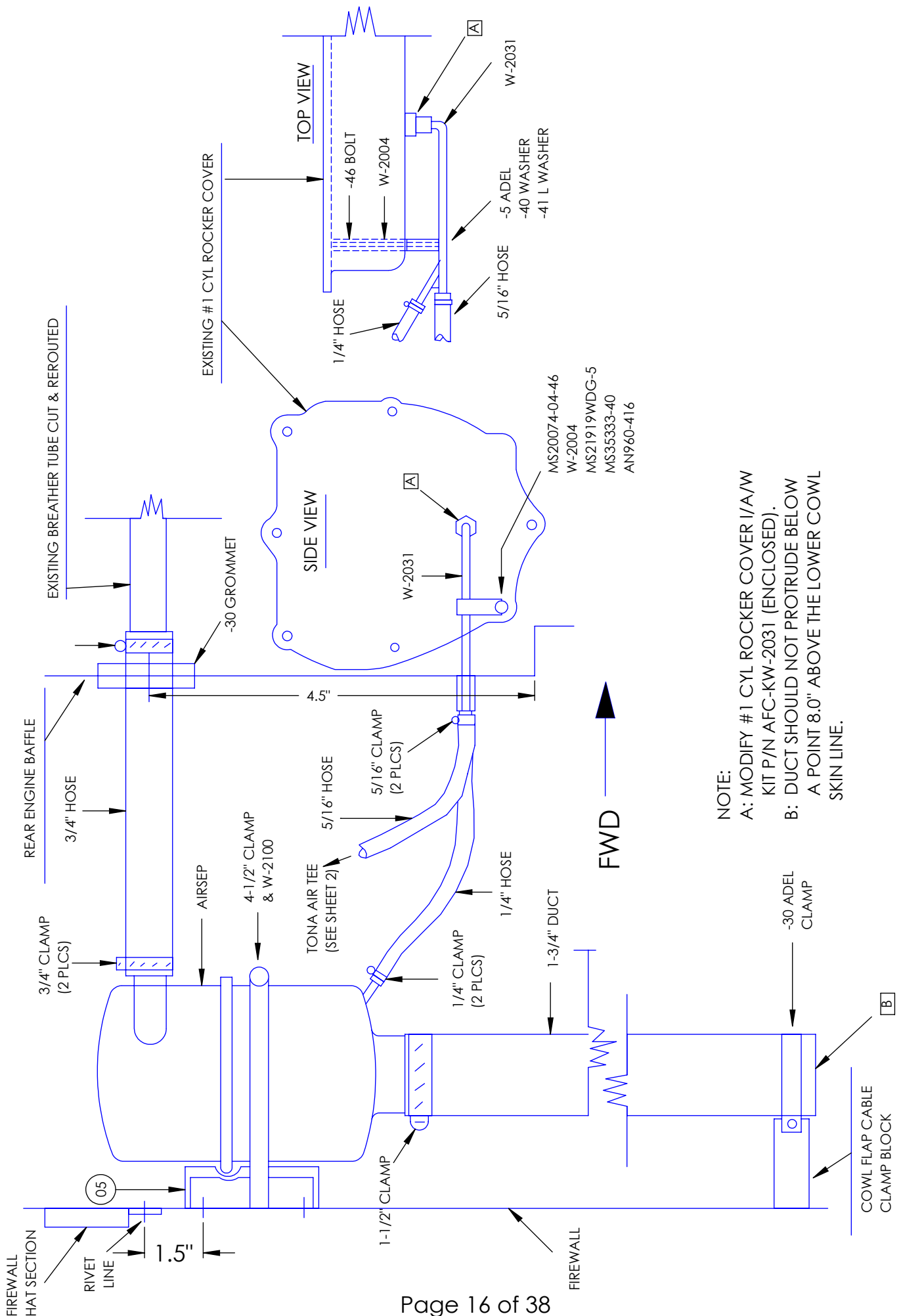

Applicability: Typical Firewall Mounted Airsep.

*Note A: Some hoses or wires may have to be rerouted so the air/oil separator will fit into position.
Reference and material per AC 43.13-1B & 2A.*

WARNING: ALL HOSES SHALL BE LOCATED AT LEAST 4.0" FROM ANY HEAT SOURCE LIKELY TO CAUSE VAPORIZATION OF THE OIL.

1. Gain access to engine compartment.
2. Using the W-2011 bracket as a template, center the bracket on the LH or RH side firewall and drill four 3/16" holes.
3. Mount the W-2011 bracket on the firewall, using the W-2150 doubler positioned on the aft side of the firewall and loosely hold in place with 4 ea #10 screws, washers and locknuts.
4. Slide the 4-1/2" clamp between the W-2011 bracket and the firewall to be used to hold the AirSep.
5. Tighten the four #10 screws installed in step #3 at this time.
6. Mount AirSep to W-2011 bracket and tighten the 4-1/2" clamp.

NOTE: Bottom drain line of the AirSep must be positioned so that it is above the level of the entrance to the engine.
Oil must be able to drain downhill.

NOTE: If the bottom drain is not "clocked" correctly for the aircraft, loosen the top 5/16-24 Nut. Then, holding the can top, twist the can bottom to get the correct orientation to provide the simplest flow to the engine. Then retighten the nut to no more than 25 in/lbs. \pm 5.

7. Using a piece of MIL6000 hose, connect the inlet of AirSep to existing engine breather line and secure with QS100 clamps.
- 8a. If no vacuum pump installed on the aircraft, drill a 5/8" hole into the engine baffle, Install an AN841-10D or equivalent fitting and AN6289-10D Nut. Run a piece of 5/8" MIL6000 hose from the fitting in the baffle to the Air-Tee, and from the Air-Tee to the 5/8" inlet on the AirSep to gain hot ram air from top of cyls.

NOTE: Make sure the word "Flow" on the Air-Tee is pointing towards the AirSep.

- 8b. If a vacuum pump is installed on the aircraft, use a piece of MIL6000 hose to connect the 5/8" exhaust fitting on the vacuum pump to the Air-Tee, and from the Air-Tee to the 5/8" inlet on the AirSep to gain hot vacuum pump exhaust.

Note: Make sure the word "Flow" on the Air-Tee is pointing towards the AirSep.

9. Determine the method of returning the recovered oil in the AirSep, to the engine. Connect an Air Syphon pump to the engine I/A/W the schematic shown on page 9.
10. Connect the 5/16" branch of the Air Syphon Pump to the 5/16" branch of the Air-Tee.
11. Connect the 1/4" branch of the Air Syphon Pump to the 1/4" drain on the AirSep
12. Connect a length of CAT-7 hose to the bottom of the AirSep and secure with a 1-3/4" clamp.
13. Secure the CAT-7 hose to an engine mount, firewall or structure using a -30 Adel Clamp.

NOTE: Do not allow the CAT-7 hose to extend out the bottom of the engine cowl. If you fail to heed this advice and allow the 1-3/4" duct to stick into the high velocity slip stream, the air/oil stream exiting the crankcase breather tube will not have proper time to coalesce inside the Air/Oil Sep and this oil laden air **will** discharge onto the belly of the aircraft, creating the same problem that the Air/Oil Sep was thoroughly designed to stop.

14. Determine weight & balance, initiate Form 337, and update the equipment list.

Applicability: Typical Firewall Mounted Airsep Installation Shown on a Beech A36 Bonanza.

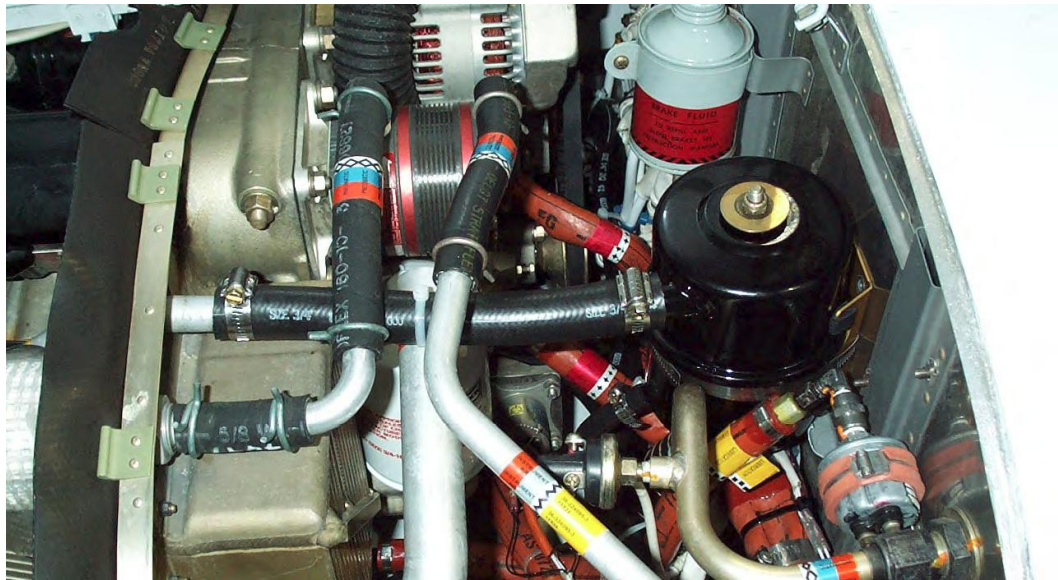

Applicability: Typical Firewall Mounted Airsep Installation Shown on a Globe Swift



Applicability: TYPICAL AIRSEP ASSYS

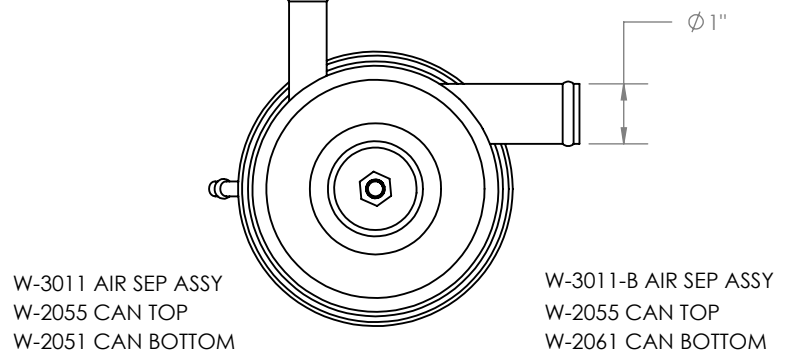
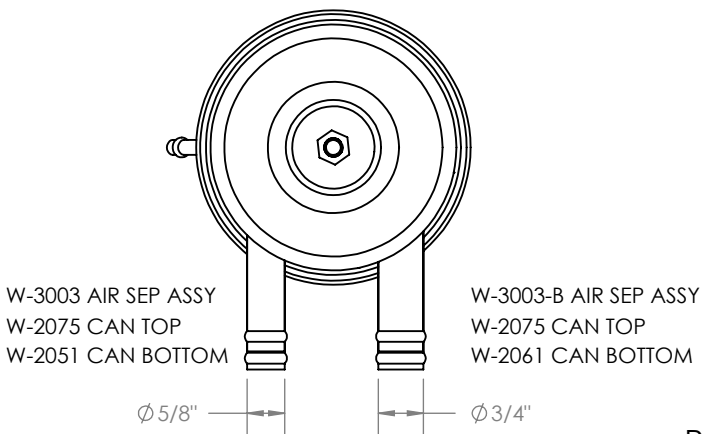
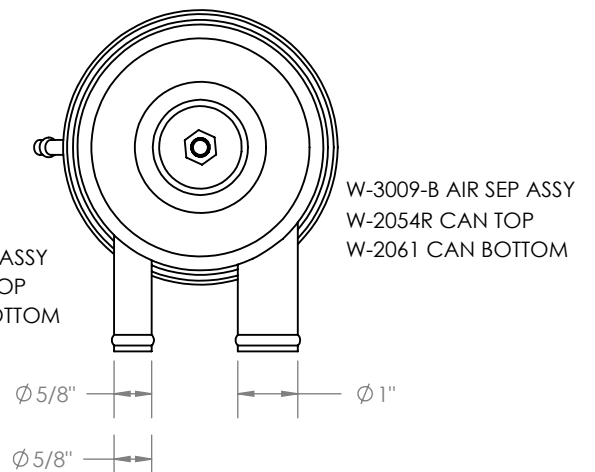
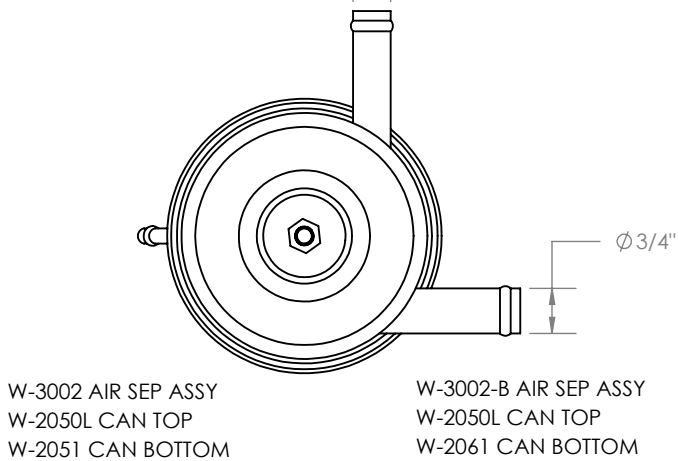
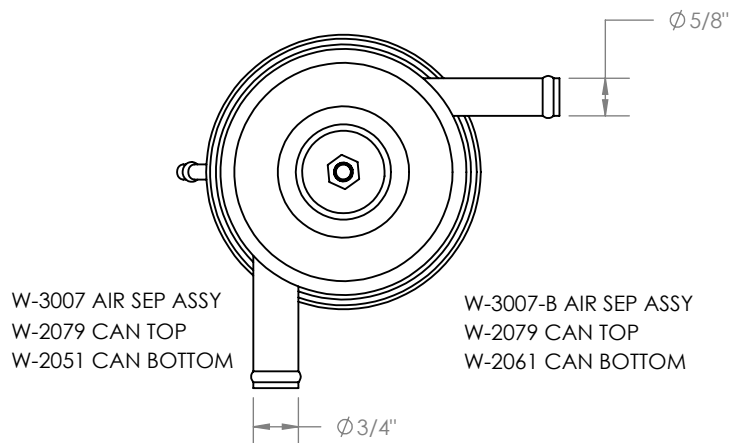
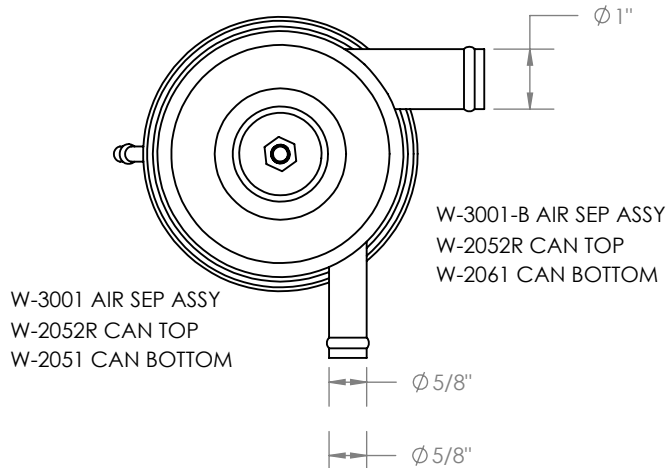
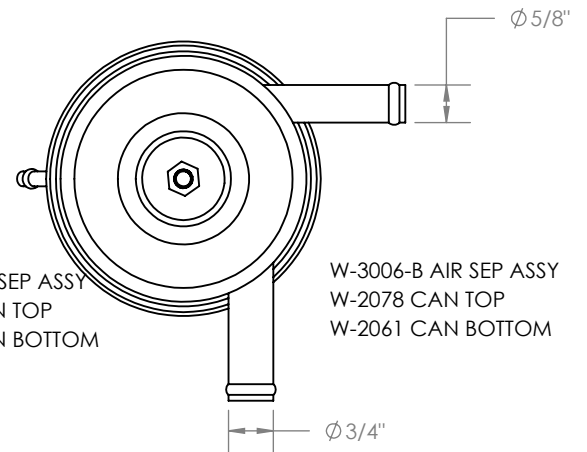
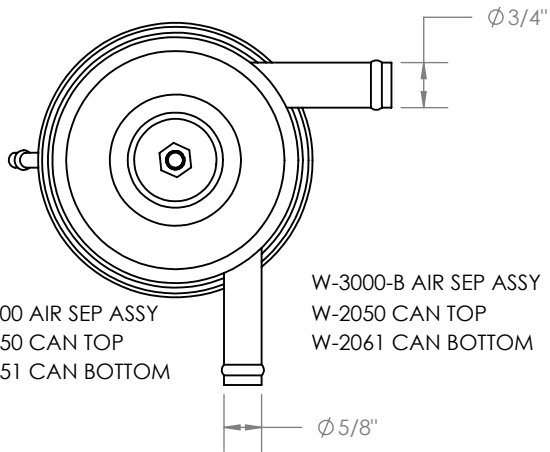

Applicability: TYPICAL AIRSEP ASSYS

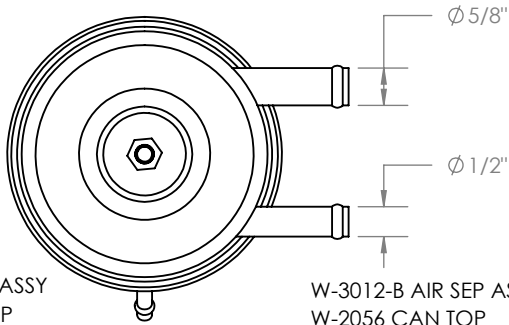

W-3012 AIR SEP ASSY
W-2056 CAN TOP
W-2051 CAN BOTTOM

W-3012-B AIR SEP ASSY
W-2056 CAN TOP
W-2061 CAN BOTTOM

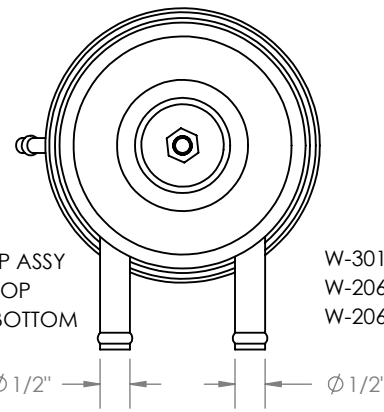

W-3016 AIR SEP ASSY
W-2060 CAN TOP
W-2051 CAN BOTTOM

W-3016-B AIR SEP ASSY
W-2060 CAN TOP
W-2061 CAN BOTTOM

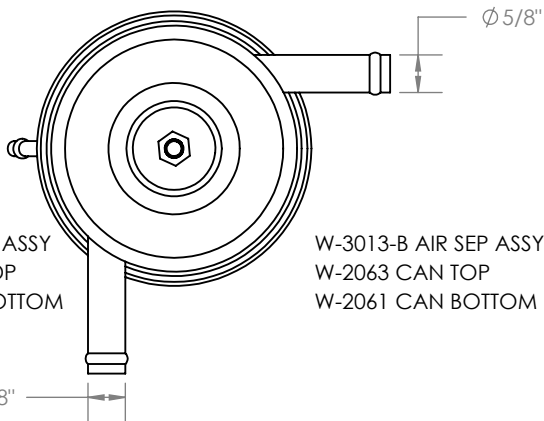

W-3013 AIR SEP ASSY
W-2063 CAN TOP
W-2051 CAN BOTTOM

W-3013-B AIR SEP ASSY
W-2063 CAN TOP
W-2061 CAN BOTTOM

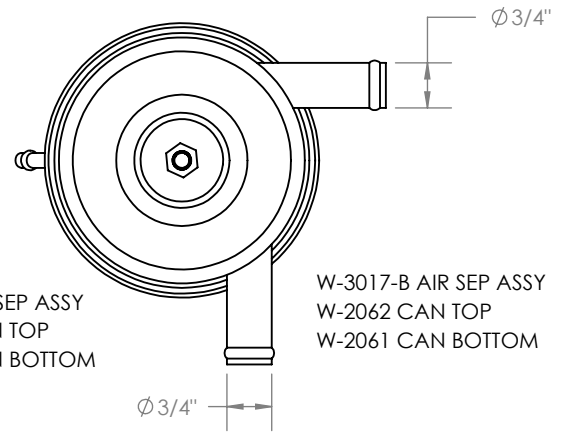

W-3017 AIR SEP ASSY
W-2062 CAN TOP
W-2051 CAN BOTTOM

W-3017-B AIR SEP ASSY
W-2062 CAN TOP
W-2061 CAN BOTTOM

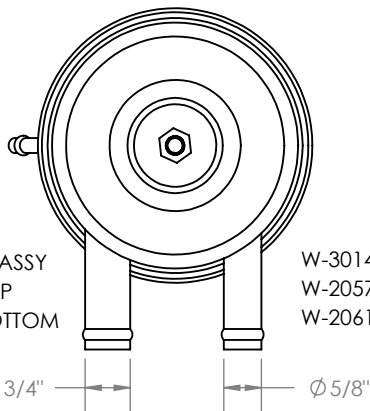

W-3014 AIR SEP ASSY
W-2057 CAN TOP
W-2051 CAN BOTTOM

W-3014-B AIR SEP ASSY
W-2057 CAN TOP
W-2061 CAN BOTTOM

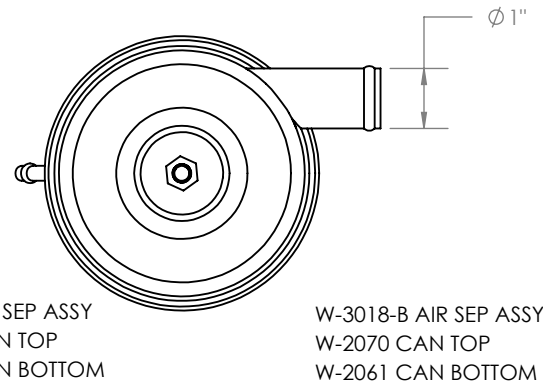

W-3018 AIR SEP ASSY
W-2070 CAN TOP
W-2051 CAN BOTTOM

W-3018-B AIR SEP ASSY
W-2070 CAN TOP
W-2061 CAN BOTTOM

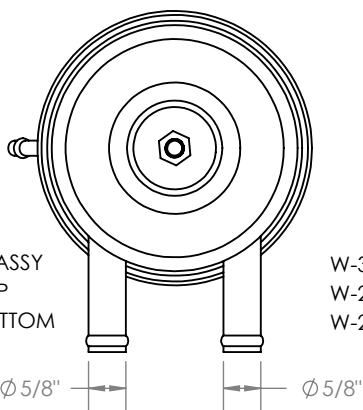

W-3015 AIR SEP ASSY
W-2059 CAN TOP
W-2051 CAN BOTTOM

W-3015-B AIR SEP ASSY
W-2059 CAN TOP
W-2061 CAN BOTTOM

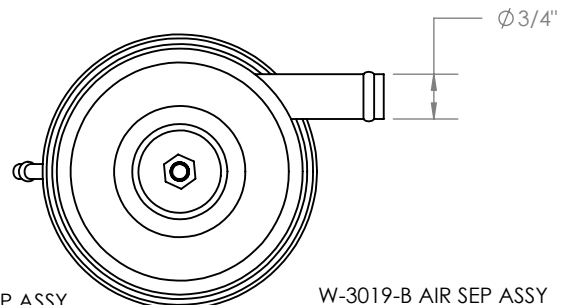

W-3019 AIR SEP ASSY
W-2071 CAN TOP
W-2051 CAN BOTTOM

W-3019-B AIR SEP ASSY
W-2071 CAN TOP
W-2061 CAN BOTTOM

Applicability: TYPICAL AIRSEP ASSYS

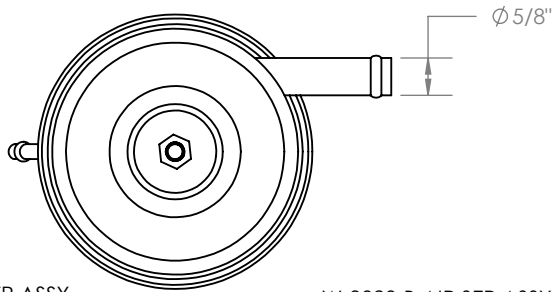

W-3020 AIR SEP ASSY
W-2072 CAN TOP
W-2051 CAN BOTTOM

W-3020-B AIR SEP ASSY
W-2072 CAN TOP
W-2061 CAN BOTTOM

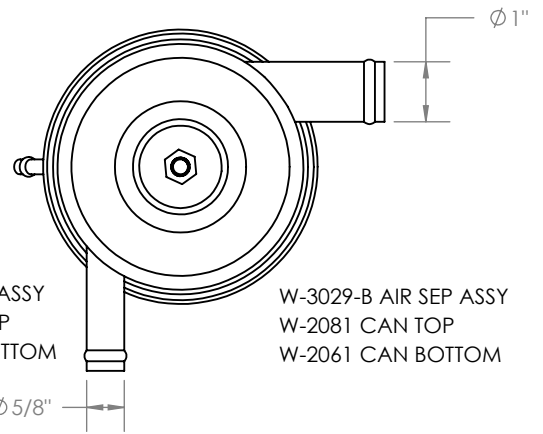

W-3029 AIR SEP ASSY
W-2081 CAN TOP
W-2051 CAN BOTTOM

W-3029-B AIR SEP ASSY
W-2081 CAN TOP
W-2061 CAN BOTTOM

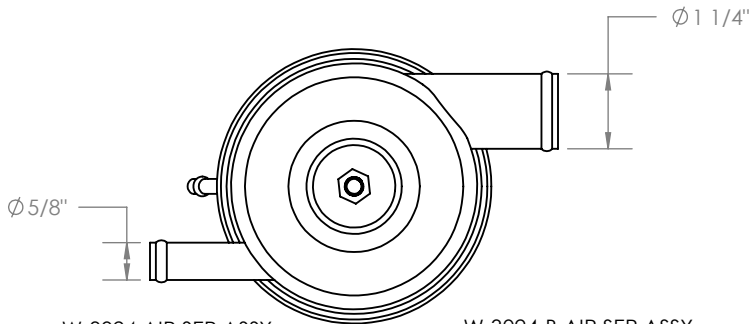

W-3024 AIR SEP ASSY
W-2074 CAN TOP
W-2051 CAN BOTTOM

W-3024-B AIR SEP ASSY
W-2074 CAN TOP
W-2061 CAN BOTTOM

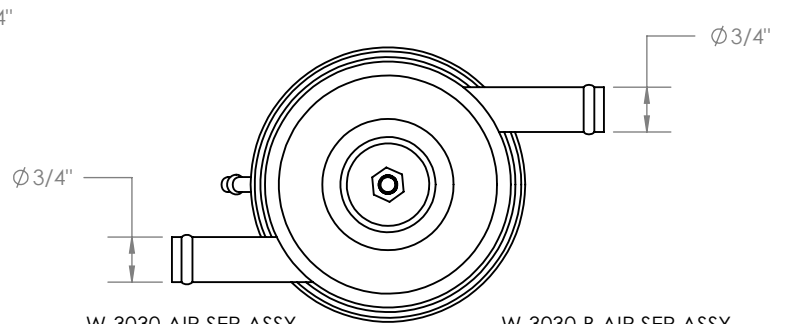

W-3030 AIR SEP ASSY
W-2082 CAN TOP
W-2051 CAN BOTTOM

W-3030-B AIR SEP ASSY
W-2082 CAN TOP
W-2061 CAN BOTTOM

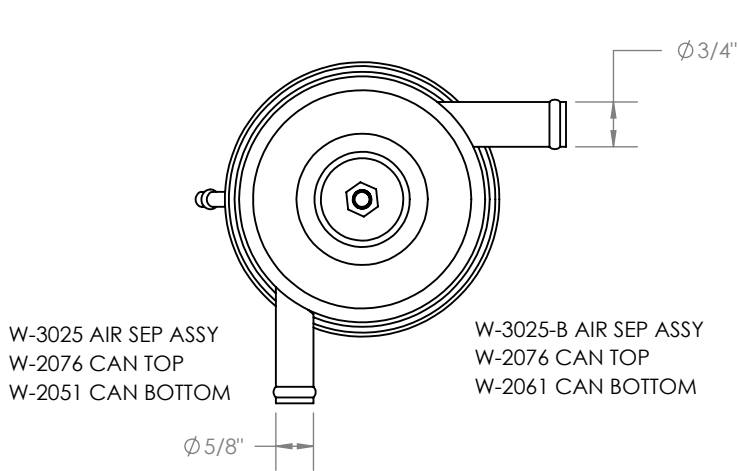

W-3025 AIR SEP ASSY
W-2076 CAN TOP
W-2051 CAN BOTTOM

W-3025-B AIR SEP ASSY
W-2076 CAN TOP
W-2061 CAN BOTTOM

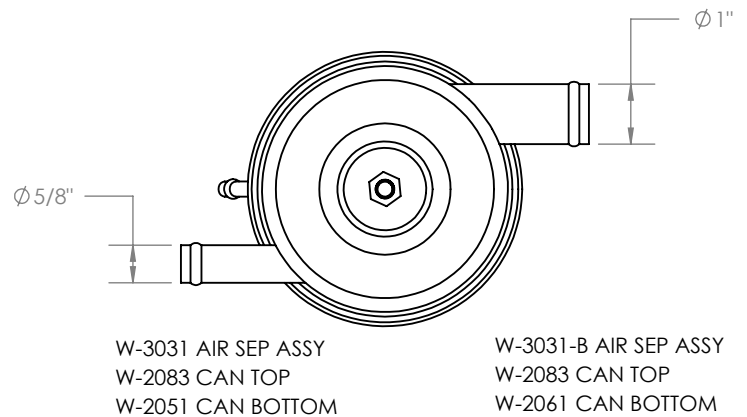

W-3031 AIR SEP ASSY
W-2083 CAN TOP
W-2051 CAN BOTTOM

W-3031-B AIR SEP ASSY
W-2083 CAN TOP
W-2061 CAN BOTTOM

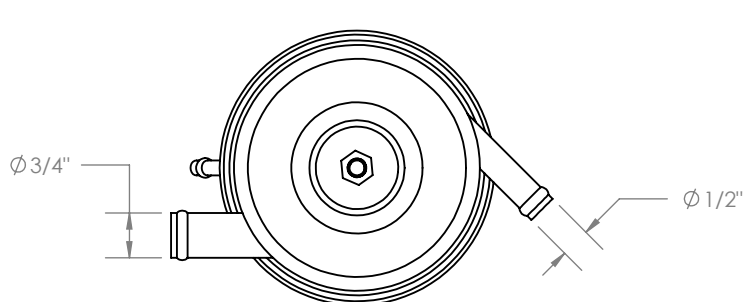

W-3027 AIR SEP ASSY
W-2077 CAN TOP
W-2051 CAN BOTTOM

W-3027-B AIR SEP ASSY
W-2077 CAN TOP
W-2061 CAN BOTTOM

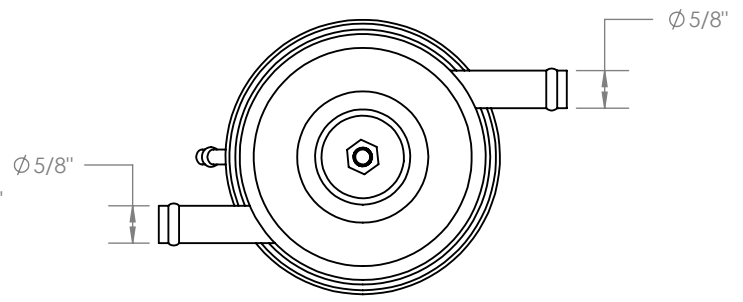

W-3032 AIR SEP ASSY
W-2084 CAN TOP
W-2051 CAN BOTTOM

W-3032-B AIR SEP ASSY
W-2084 CAN TOP
W-2061 CAN BOTTOM

Applicability: TYPICAL AIRSEP ASSYS

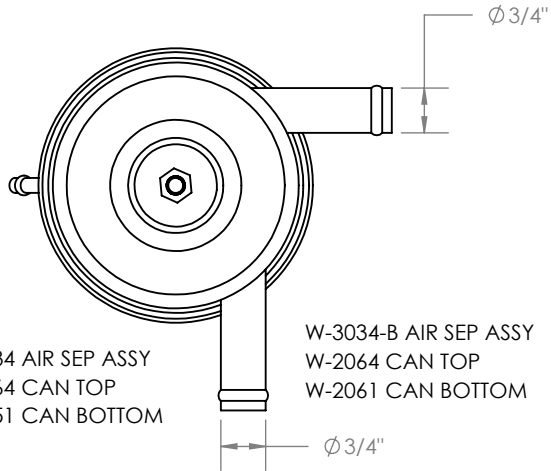

W-3034 AIR SEP ASSY
W-2064 CAN TOP
W-2051 CAN BOTTOM

W-3034-B AIR SEP ASSY
W-2064 CAN TOP
W-2061 CAN BOTTOM

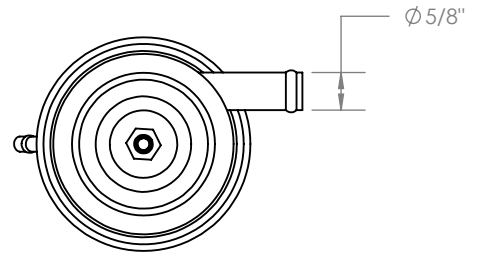

W-4000-C AIR SEP ASSY
W-4026 CAN TOP
W-4015 CAN BOTTOM

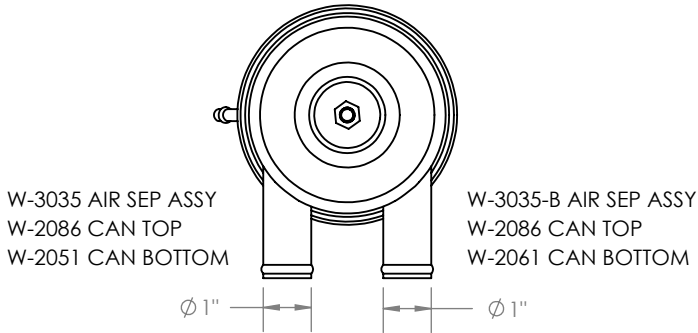

W-3035 AIR SEP ASSY
W-2086 CAN TOP
W-2051 CAN BOTTOM

W-3035-B AIR SEP ASSY
W-2086 CAN TOP
W-2061 CAN BOTTOM

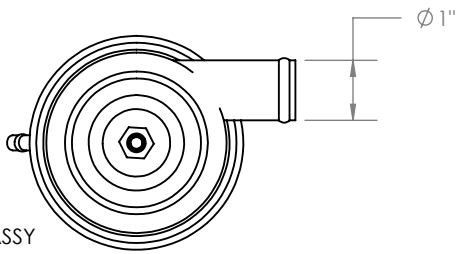

W-4000-A AIR SEP ASSY
W-4022 CAN TOP
W-4015 CAN BOTTOM

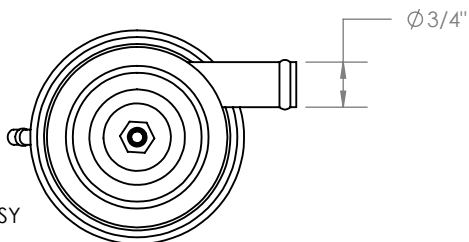

W-4000-B AIR SEP ASSY
W-4024 CAN TOP
W-4015 CAN BOTTOM

Oil return Method List Selection Guide:**FOR AIRSEP™**

<u>P/N</u>	<u>DESCRIPTION</u>	<u>ENGINE</u>	
KW-2031	Rocker Cover Mod	TCM Engines	
		TCM IO470-D/E/F/G/H/L/LO/P/R/S/T/U/V/VO & LIO470-A	[STC# SE92WE]
		TCM TSIO470-B/C/D	[STC# SE93WE]
		TCM IO520-A/B/BA/C/D/E/F/J/K/L/M	[STC# SE94WE]
		TCM O470-B/G/H/K/L/M/N/P/R/S/T/U	[STC# SE95WE]
		TCM O470-B-CI/G-CI/K-CI/L-CI/M-CI	[STC# SE95WE]
		TCM IO470-A/C	[STC# SE95WE]
		TCM TSIO520-A/B/C/D/E/F/G/H/J/K/L/M/N/P/R	[STC# SE96WE]
W-2008	AirSyphon Pump	Lyc O235-O540 Series and TCM A65-O550 series	
W-2014	AirSyphon Pump	All Engines using Pushrod Shroud Tube Option	
W-2031	AirSyphon Pump	Lyc O235-O540 Series and	
		TCM IO470-D/E/F/G/H/L/LO/P/R/S/T/U/V/VO & LIO470-A	[STC# SE92WE]
		TCM TSIO470-B/C/D	[STC# SE93WE]
		TCM IO520-A/B/BA/C/D/E/F/J/K/L/M	[STC# SE94WE]
		TCM O470-B/G/H/K/L/M/N/P/R/S/T/U	[STC# SE95WE]
		TCM O470-B-CI/G-CI/K-CI/L-CI/M-CI	[STC# SE95WE]
		TCM IO470-A/C	[STC# SE95WE]
		TCM TSIO520-A/B/C/D/E/F/G/H/J/K/L/M/N/P/R	[STC# SE96WE]
W-2046	AirSyphon Pump	Lyc O235-O540 Series, #3 or #5 Cyl Drain	
W-2046-1	AirSyphon Pump	Lyc O320-H series engines with 1/2" Cyl Drains	
W-2046-2	AirSyphon Pump	Lyc O235-O540 Series, #4 or #6 Cyl Drain	
W-2046-3	AirSyphon Pump	Lyc O235-O540 Series, #4 or #6 Cyl Drain	
W-2046-4	AirSyphon Pump	Lyc IO360 & IO540 Series, #3 or #5 Cyl Drain	
W-2046-5	AirSyphon Pump	Lyc IO360 & IO540 Series, #4 or #6 Cyl Drain	
W-2154-1	Pushrod Shroud Tube	TCM 470/520/550 Engines with Single Rocker Cover	
W-2154-2	Pushrod Shroud Tube	TCM 470/520/550 Engines with Single Rocker Cover	
W-2154-3	Pushrod Shroud Tube	TCM 470/520/550 Engines with Single Rocker Cover	
W-2154-4	Pushrod Shroud Tube	TCM 470/520/550 Engines with Single Rocker Cover	
W-2154-5	Pushrod Shroud Tube	TCM 470/520/550 Engines with Single Rocker Cover	
W-2154-6	Pushrod Shroud Tube	TCM 470/520/550 Engines with Single Rocker Cover	
W-2154-8	Pushrod Shroud Tube	TCM 470/520/550 Engines with Single Rocker Cover	
W-2155-1	Pushrod Shroud Tube	TCM IO550G/N/R/P Engines with Dual Rocker Covers	
W-2155-2	Pushrod Shroud Tube	TCM IO550G/N/R/P Engines with Dual Rocker Covers	
W-2155-3	Pushrod Shroud Tube	TCM IO550G/N/R/P Engines with Dual Rocker Covers	
W-2156-1	Pushrod Shroud Tube	TCM IO/TSIO240 & IO/TSIO360 Engines with Dual Rocker Covers	
W-2157	Rocker Cover Mod	All Franklin Engines	

FOR MINISEP™

<u>P/N</u>	<u>DESCRIPTION</u>	<u>ENGINE</u>
AN840-4D	Straight Fitting	ALL
AN842-4D	90° Fitting	ALL
AN844-4D	45° Fitting	ALL
AN912-3D	Reducer Fitting	ALL

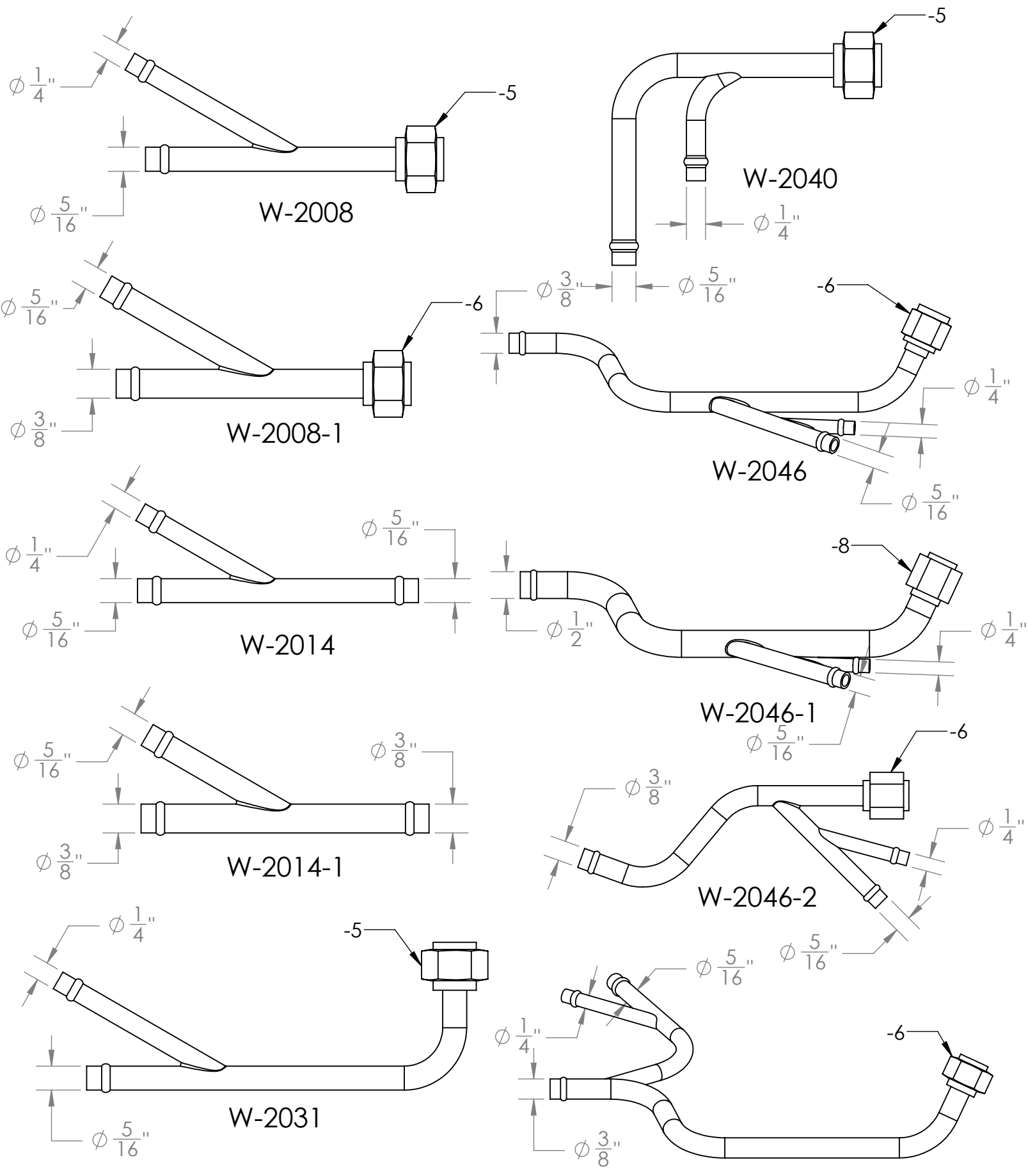

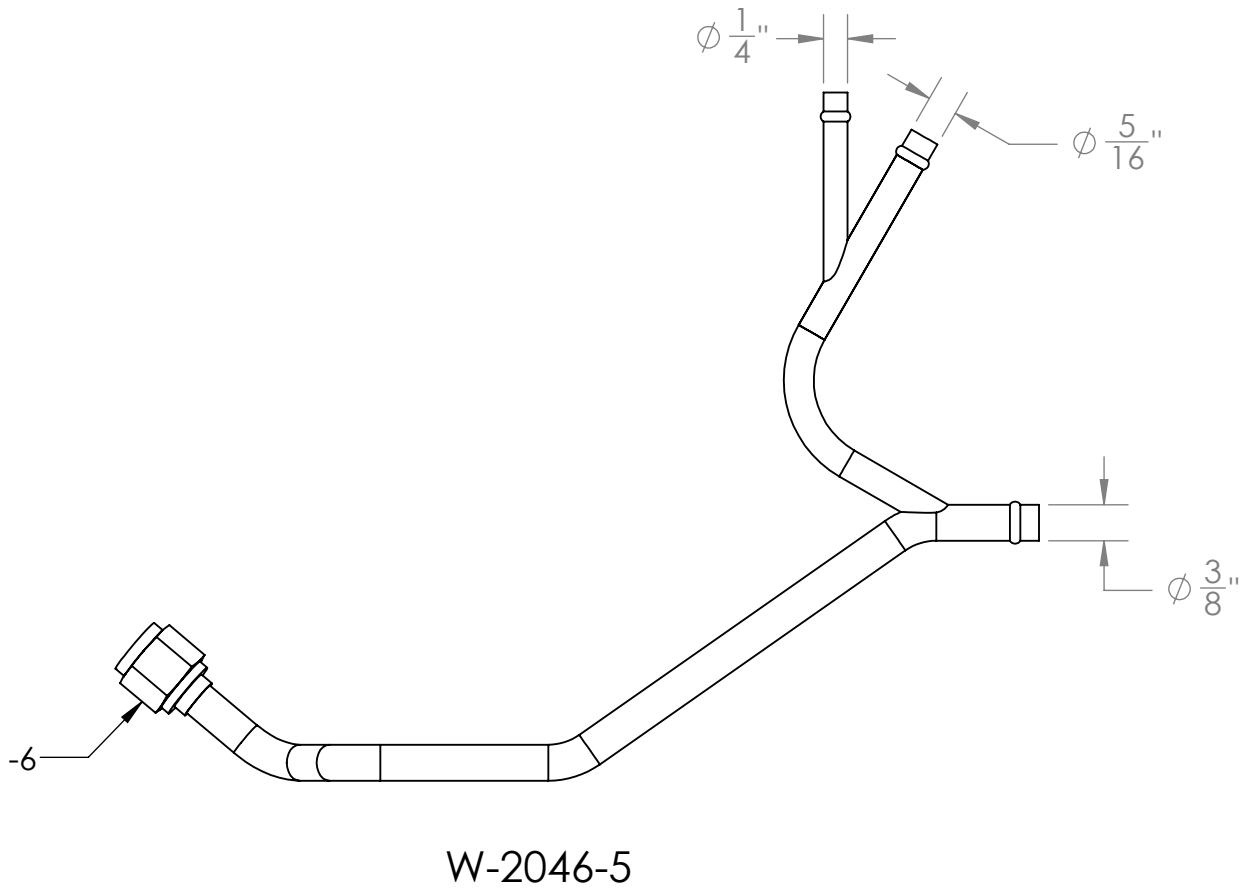
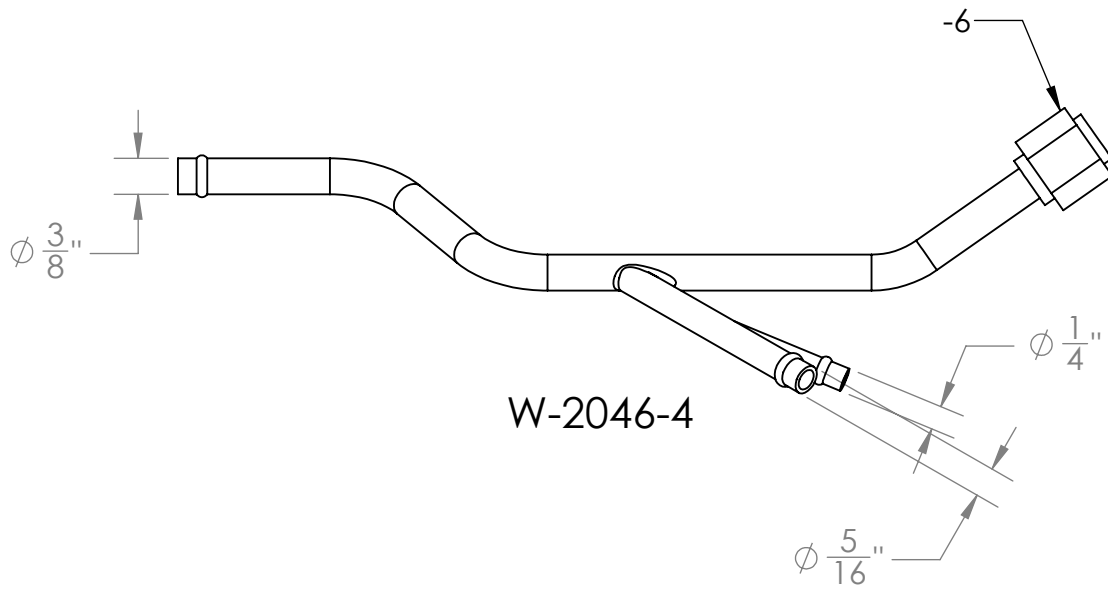

Applicability: SELECT ENGINE/OIL RETURN METHOD

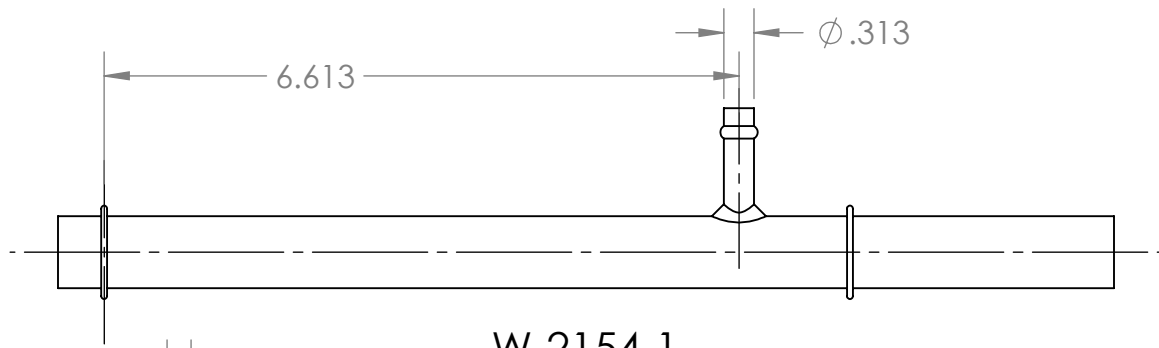

W-2154-1

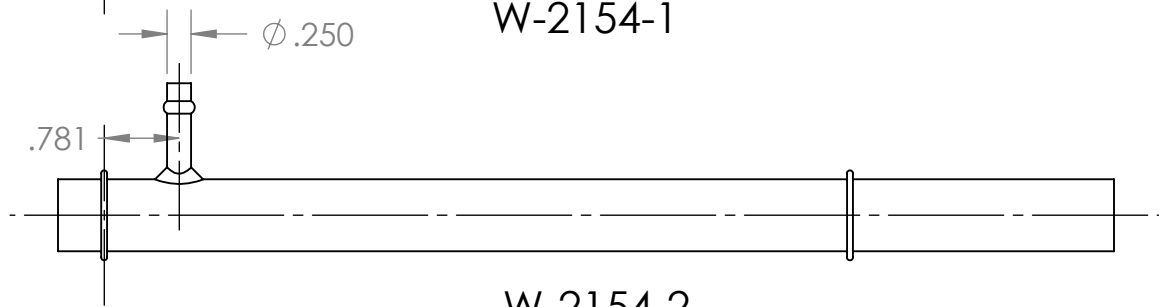

W-2154-2

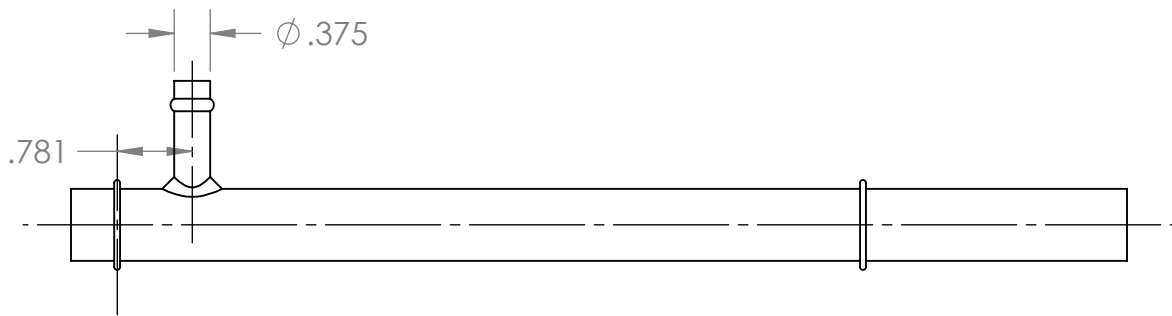

W-2154-3

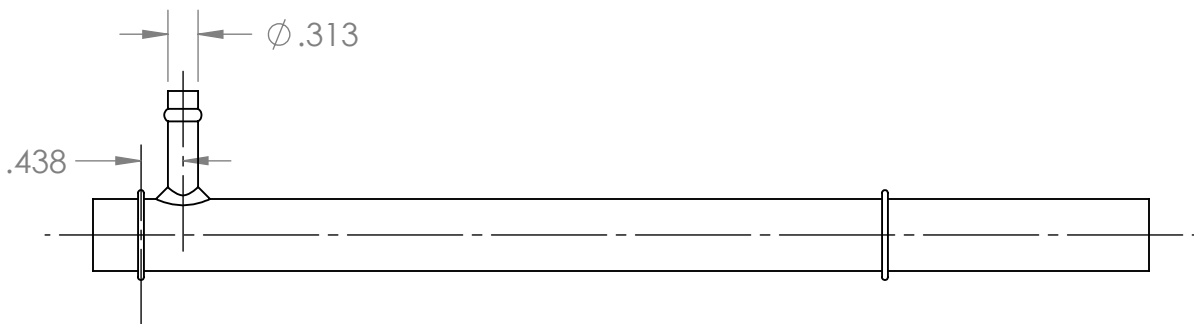

W-2154-4

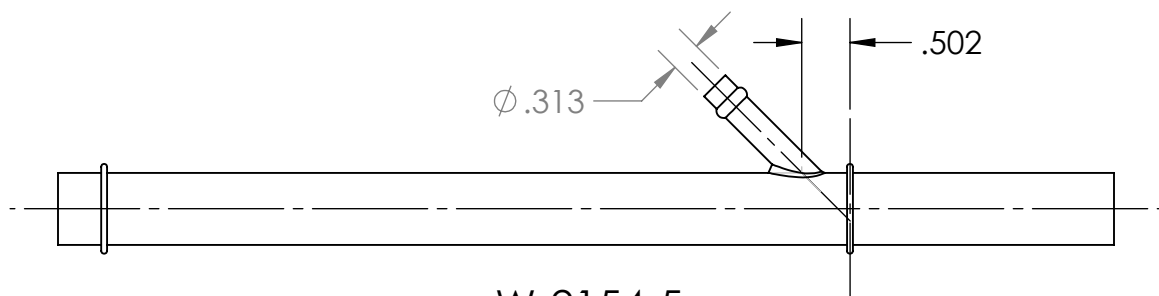

W-2154-5

Applicability: SELECT ENGINE/OIL RETURN METHOD

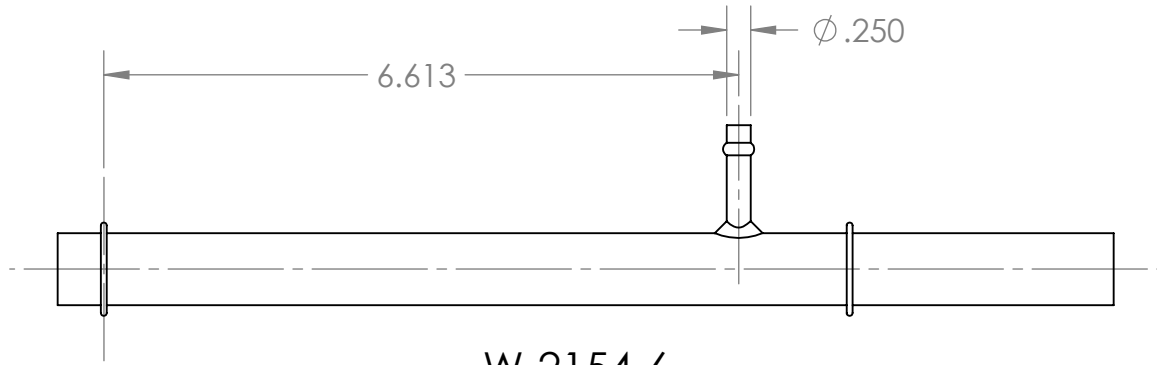

W-2154-6

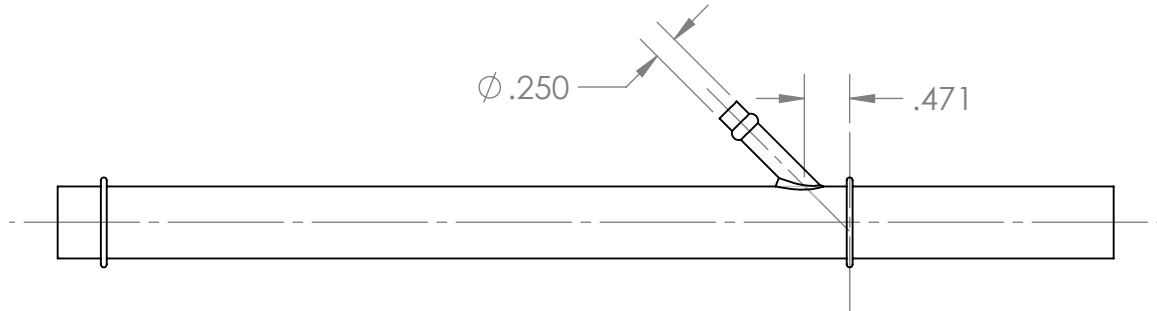

W-2154-8

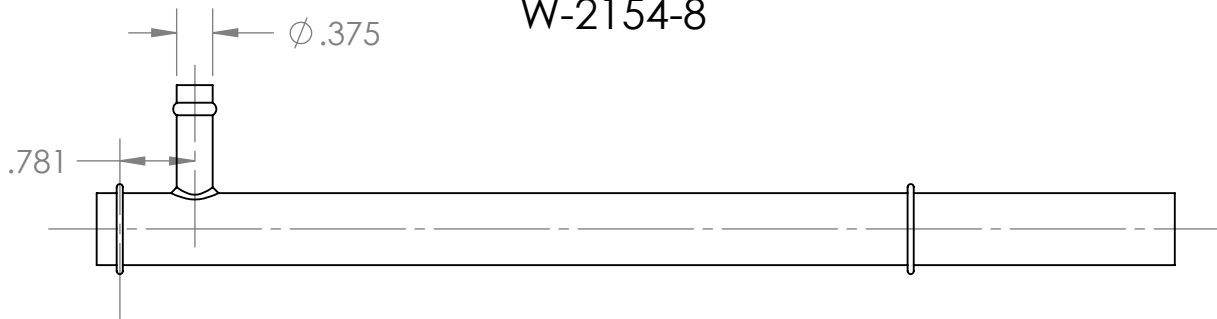

W-2155-1

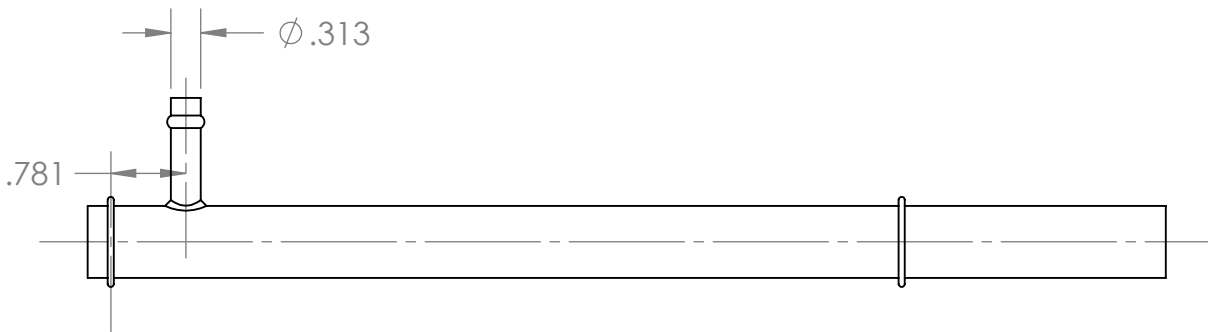

W-2155-2

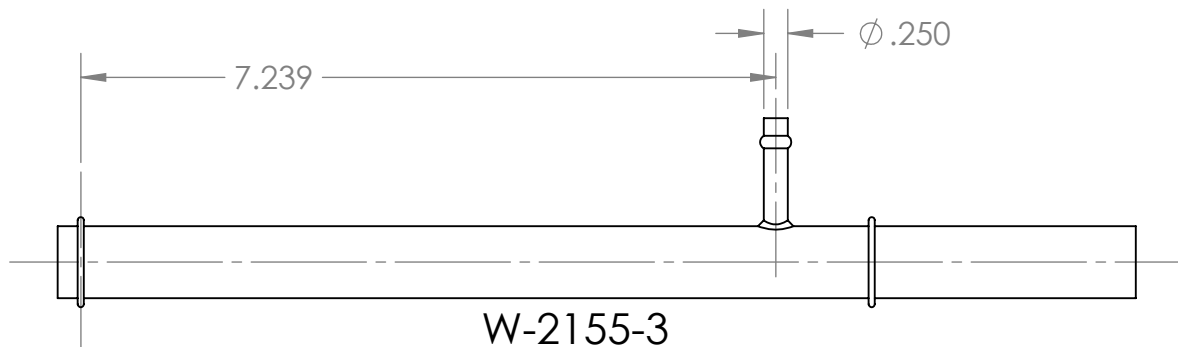

W-2155-3

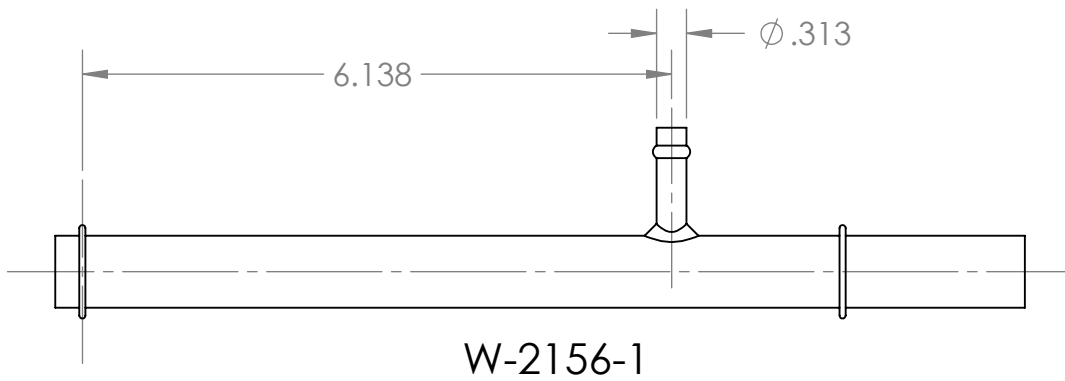

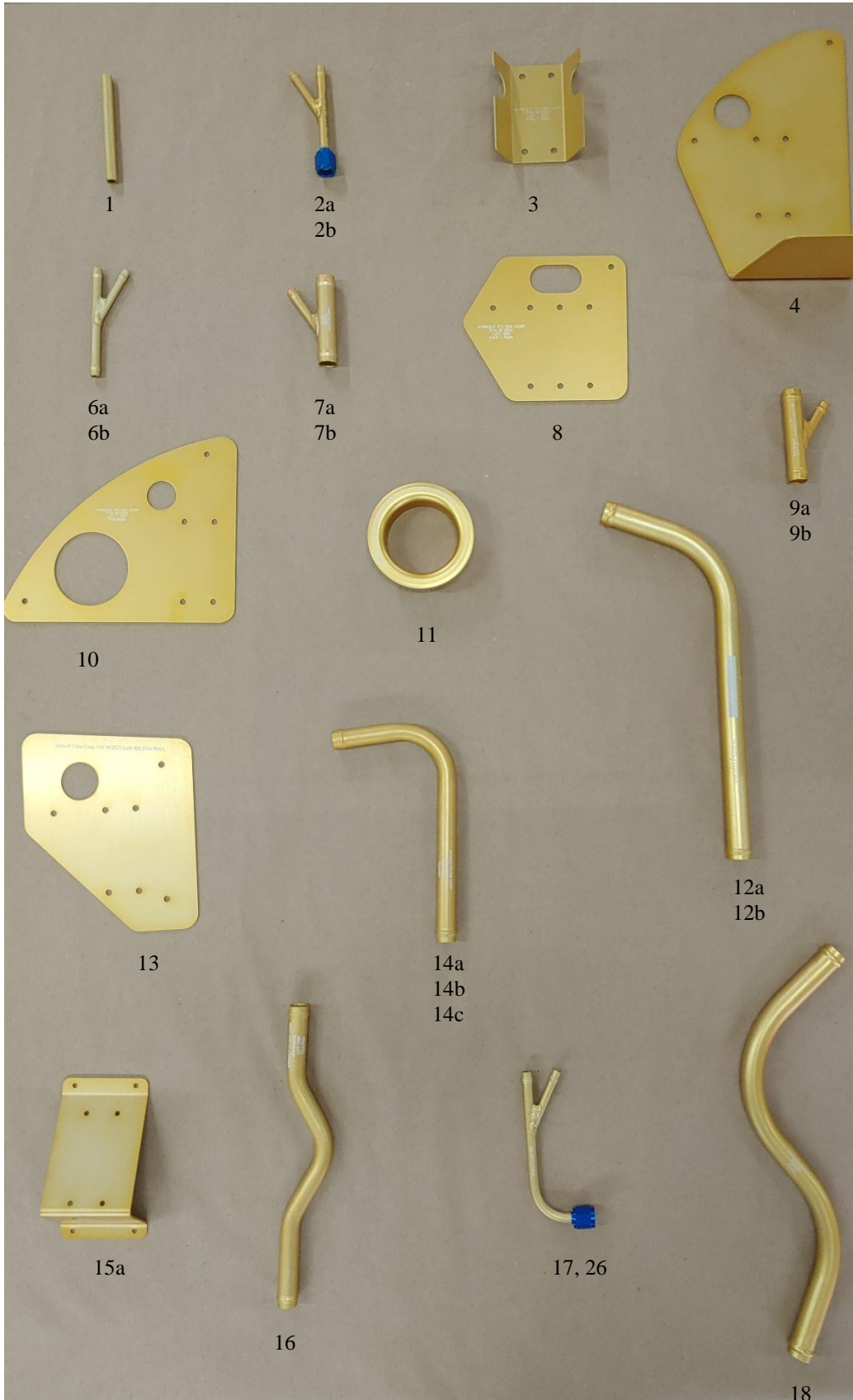

Figure 1

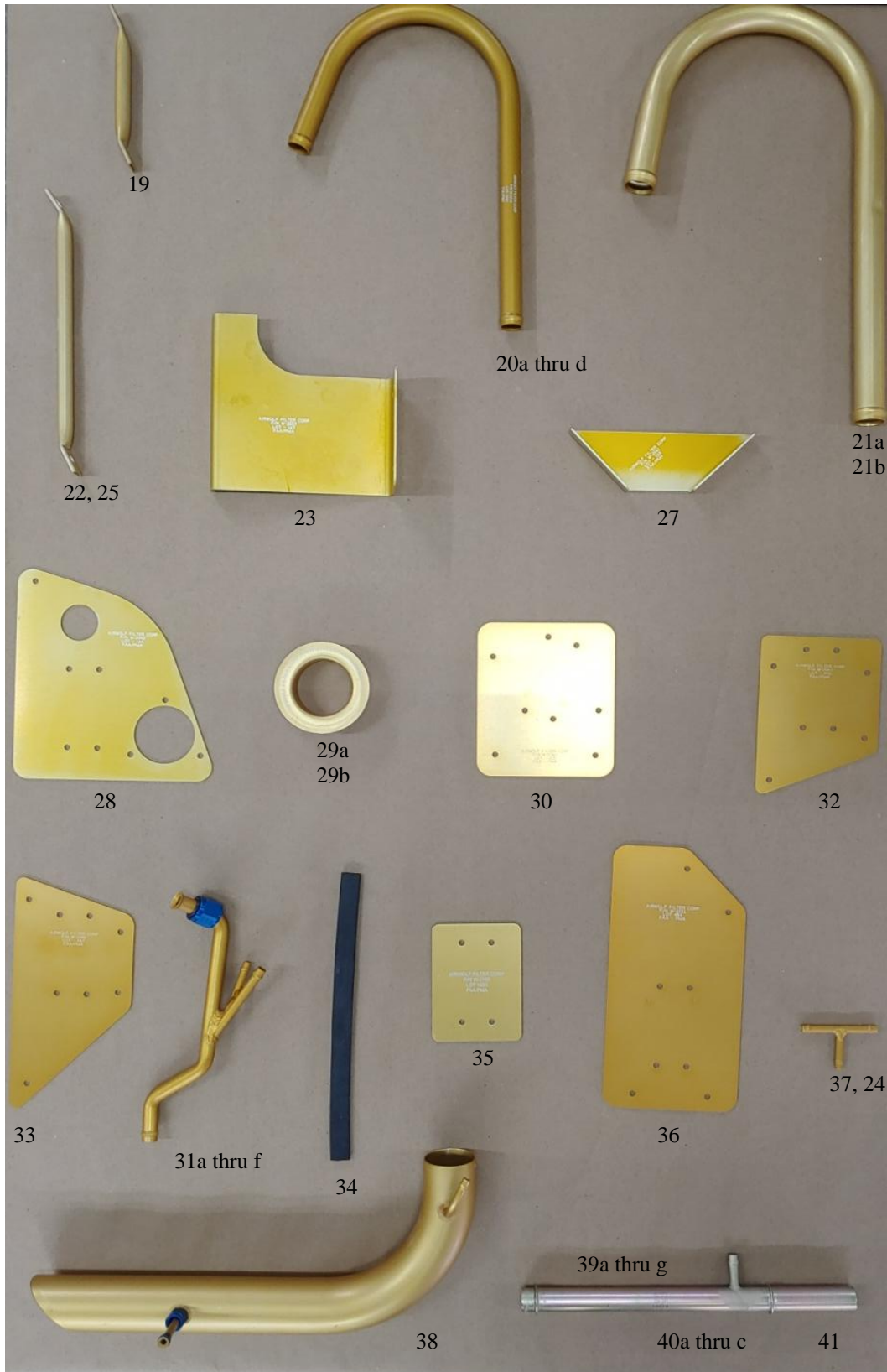

Figure 2

Applicability: Typical Airsep Parts Available to Install on Aircraft.

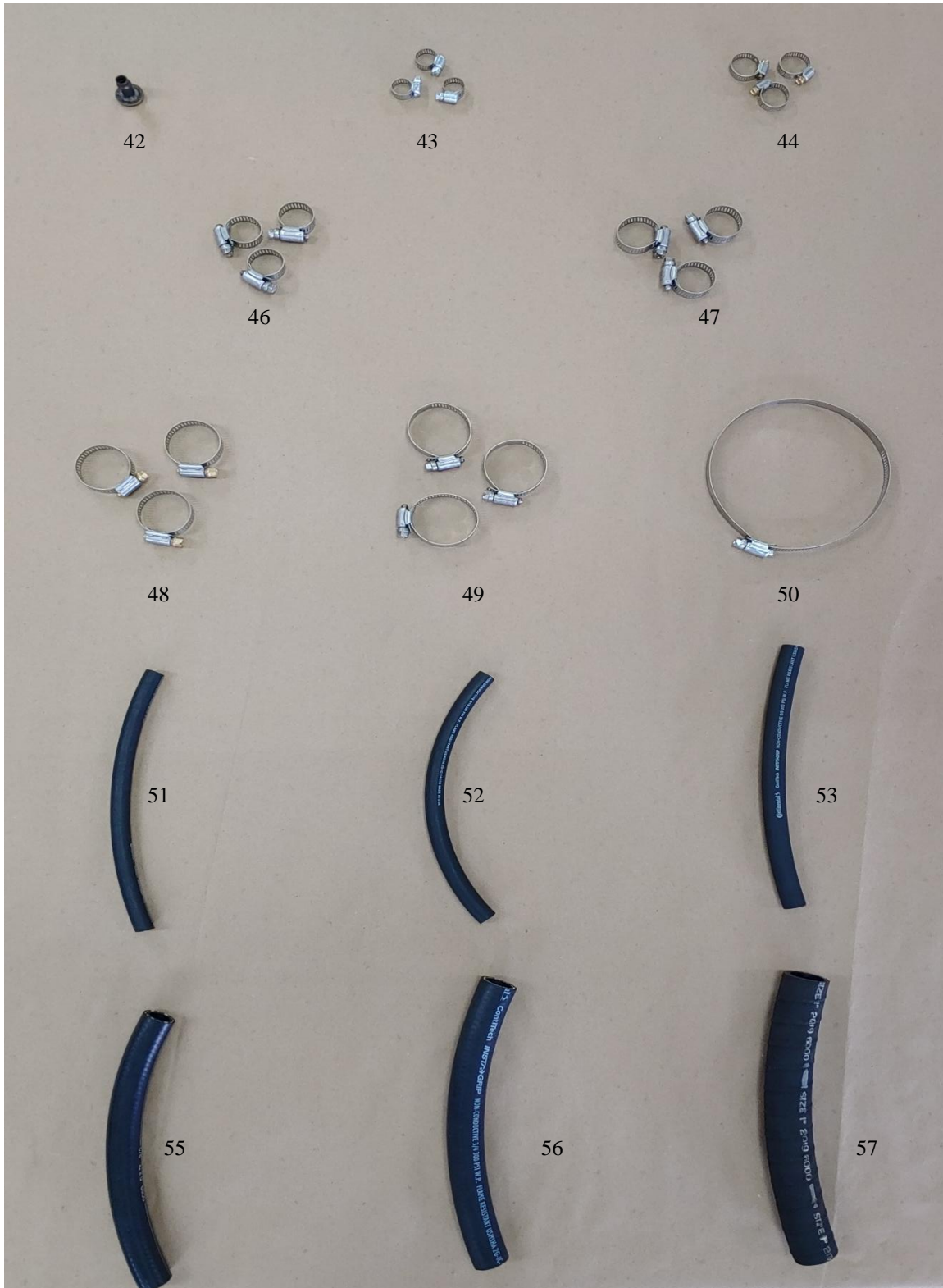

Figure 3

Applicability: Typical Airsep Parts Available to Install on Aircraft.**AirSep Parts List**

<u>Fig & Index</u>	<u>Part Number</u>	<u>Description</u>	<u>Quantity</u>
1 - 1.	W-2004	Bushing	(1)
1 - 2a.	W-2008	AirSyphon Pump	(1)
1 - 2b.	W-2008-1	AirSyphon Pump	(1)
1 - 3.	W-2011	Bracket	(1)
1 - 4.	W-2012	Doubler	(1)
5.	W-2013	Duct Bracket	(1)
1 - 6a.	W-2014	AirSyphon Pump	(1)
1 - 6b.	W-2014-1	AirSyphon Pump	(1)
1 - 7a.	W-2018	1/2" O.D. Air-Tee	(1)
1 - 7b.	W-2018-1	5/8" O.D. Air-Tee	(1)
1 - 8.	W-2021	Doubler	(1)
1 - 9a.	W-2022	Air-Tee	(1)
1 - 9b.	W-2022-1	Air-Tee	(1)
1 - 10.	W-2023	Doubler	(1)
1 - 11.	W-2024	Flange	(1)
1 - 12a.	W-2025-1	Breather Tube	(1)
1 - 12b.	W-2025-2	Breather Tube	(1)
1 - 13.	W-2027	Doubler	(1)
1 - 14a.	W-2028-1	Breather Tube	(1)
1 - 14b.	W-2028-2	Breather Tube	(1)
1 - 14c.	W-2028-3	Breather Tube	(1)
1 - 15a.	W-2029	Bracket	(1)
1 - 15b.	W-2029-1	Bracket	(1)
1 - 16.	W-2030	Breather Tube	(1)
1 - 17.	W-2031	AirSyphon Pump	(1)
1 - 18.	W-2032	Breather Tube	(1)
2 - 19.	W-2033	Brace	(1)
2 - 20a.	W-2034	Breather Tube	(1)
2 - 20b.	W-2034-1	Breather Tube	(1)
2 - 20c.	W-2034-2	Breather Tube	(1)
2 - 20d.	W-2034-3	Breather Tube	(1)
2 - 21a.	W-2035	Breather Tube	(1)
2 - 21b.	W-2035-1	Breather Tube	(1)
2 - 22.	W-2036	Brace	(1)
2 - 23.	W-2037	Bracket	(1)
2 - 24.	W-2038	Tee	(1)
2 - 25.	W-2039	Brace	(1)
2 - 26.	W-2040	AirSyphon Pump	(1)
2 - 27.	W-2041	Brace	(1)
2 - 28.	W-2042	Doubler	(1)
2 - 29a.	W-2043	Flange	(1)
2 - 29b.	W-2043-1	Flange	(1)
2 - 30.	W-2045	Doubler, C-172	(1)
2 - 31a.	W-2046	AirSyphon Pump	(1)
2 - 31b.	W-2046-1	AirSyphon Pump	(1)
2 - 31c.	W-2046-2	AirSyphon Pump	(1)
2 - 31d.	W-2046-3	AirSyphon Pump	(1)
2 - 31e.	W-2046-4	AirSyphon Pump	(1)
2 - 31f.	W-2046-5	AirSyphon Pump	(1)
2 - 32.	W-2047	Doubler, Maule	(1)
2 - 33.	W-2048	Doubler, Maule	(1)
2 - 34.	W-2100	"C" Channel	(1)
2 - 35.	W-2150	Doubler	(1)
2 - 36.	W-2151	Bracket	(1)
2 - 37.	W-2152	Air-Tee	(1)
2 - 38.	W-2153	Discharge Tube	(1)
2 - 39a.	W-2154-1	Shroud Tube	(1)
2 - 39b.	W-2154-2	Shroud Tube	(1)

Applicability: Typical Airsep Parts Available to Install on Aircraft.**AirSep Parts List**

<u>Fig & Index</u>	<u>Part Number</u>	<u>Description</u>	<u>Quantity</u>
2 - 39c.	W-2154-3	Shroud Tube	(1)
2 - 39d.	W-2154-4	Shroud Tube	(1)
2 - 39e	W-2154-5	Shroud Tube	(1)
2 - 39f.	W-2154-6	Shroud Tube	(1)
2 - 39g.	W-2154-8	Shroud Tube	(1)
2 - 40a.	W-2155-1	Shroud Tube	(1)
2 - 40b.	W-2155-2	Shroud Tube	(1)
2 - 40c.	W-2155-3	Shroud Tube	(1)
2 - 41.	W-2156-1	Shroud Tube	(1)
3 - 42.	W-2157	Franklin Rocker Box Mod	(1)
3 - 43	MM-4	1/4" I.D. Hose Clamp	A/R
3 - 44	MM-5	5/16" I.D. Hose Clamp	A/R
45	QS100M08H	1/2" I.D. Hose Clamp	A/R
3 - 46	QS100M10H	5/8" I.D. Hose Clamp	A/R
3 - 47	QS100M12H	3/4" I.D. Hose Clamp	A/R
3 - 48	QS100M16H	1" I.D. Hose Clamp	A/R
3 - 49	QS100M24H	1-3/4" I.D. Hose Clamp	A/R
3 - 50	QS100M72H	4-1/2" I.D. Hose Clamp	A/R
3 - 51	Hose-1/4	Airwolf 1/4" I.D. Hose	A/R
3 - 52	Hose-5/16	Airwolf 5/16" I.D. Hose	A/R
3 - 53	Hose-3/8	Airwolf 3/8" I.D. Hose	A/R
54	Hose-1/2	Airwolf 1/2" I.D. Hose	A/R
3 - 55	Hose-5/8	Airwolf 5/8" I.D. Hose	A/R
3 - 56	Hose-3/4	Airwolf 3/4" I.D. Hose	A/R
3 - 57	Hose-1	Airwolf 1" I.D. Hose	A/R
58	Hose-1-1/4	Airwolf 1-1/4" I.D. Hose	A/R

Applicability: Typical Airsep Assembly Part Number List & Description.**AirSeps for Breather & Wet or Dry Vacuum Pumps**

<u>P/N</u>	<u>DESCRIPTION</u>
W-3000	AirSep Assy, 1/4" Drain
W-3000-B	AirSep Assy, 3/8" Drain
W-3001	AirSep Assy, 1/4" Drain
W-3001-B	AirSep Assy, 3/8" Drain
W-3002	AirSep Assy, 1/4" Drain
W-3002-B	AirSep Assy, 3/8" Drain
W-3003	AirSep Assy, 1/4" Drain
W-3003-B	AirSep Assy, 3/8" Drain
W-3006	AirSep Assy, 1/4" Drain
W-3006-B	AirSep Assy, 3/8" Drain
W-3007	AirSep Assy, 1/4" Drain
W-3007-B	AirSep Assy, 3/8" Drain
W-3009	AirSep Assy, 1/4" Drain
W-3009-B	AirSep Assy, 3/8" Drain
W-3011	AirSep Assy, 1/4" Drain
W-3011-B	AirSep Assy, 3/8" Drain
W-3012	AirSep Assy, 1/4" Drain
W-3012-B	AirSep Assy, 3/8" Drain
W-3013	AirSep Assy, 1/4" Drain
W-3013-B	AirSep Assy, 3/8" Drain
W-3014	AirSep Assy, 1/4" Drain
W-3014-B	AirSep Assy, 3/8" Drain
W-3015	AirSep Assy, 1/4" Drain
W-3015-B	AirSep Assy, 3/8" Drain
W-3016	AirSep Assy, 1/4" Drain
W-3016-B	AirSep Assy, 3/8" Drain
W-3017	AirSep Assy, 1/4" Drain
W-3017-B	AirSep Assy, 3/8" Drain
W-3018	AirSep Assy, 1/4" Drain
W-3018-B	AirSep Assy, 3/8" Drain
W-3019	AirSep Assy, 1/4" Drain
W-3019-B	AirSep Assy, 3/8" Drain
W-3020	AirSep Assy, 1/4" Drain
W-3020-B	AirSep Assy, 3/8" Drain
W-3024	AirSep Assy, 1/4" Drain
W-3024-B	AirSep Assy, 3/8" Drain
W-3025	AirSep Assy, 1/4" Drain
W-3025-B	AirSep Assy, 3/8" Drain
W-3027	AirSep Assy, 1/4" Drain
W-3027-B	AirSep Assy, 3/8" Drain
W-3029	AirSep Assy, 1/4" Drain
W-3029-B	AirSep Assy, 3/8" Drain
W-3030	AirSep Assy, 1/4" Drain
W-3030-B	AirSep Assy, 3/8" Drain
W-3031	AirSep Assy, 1/4" Drain
W-3031-B	AirSep Assy, 3/8" Drain
W-3032	AirSep Assy, 1/4" Drain
W-3032-B	AirSep Assy, 3/8" Drain
W-3034	AirSep Assy, 1/4" Drain
W-3034-B	AirSep Assy, 3/8" Drain
W-3035	AirSep Assy, 1/4" Drain
W-3035-B	AirSep Assy, 3/8" Drain

MiniSeps for:**Engine Breathers or Wet Vacuum Pumps**

<u>P/N</u>	<u>DESCRIPTION</u>
W-4000-A	MiniSep Assy, 1" Inlet
W-4000-B	MiniSep Assy, 3/4" Inlet
W-4000-C	MiniSep Assy, 5/8" Inlet

Applicability: Typical Mini Sep Parts Required to Install on Aircraft Engine Breather line or Wet Vacuum Pumps.

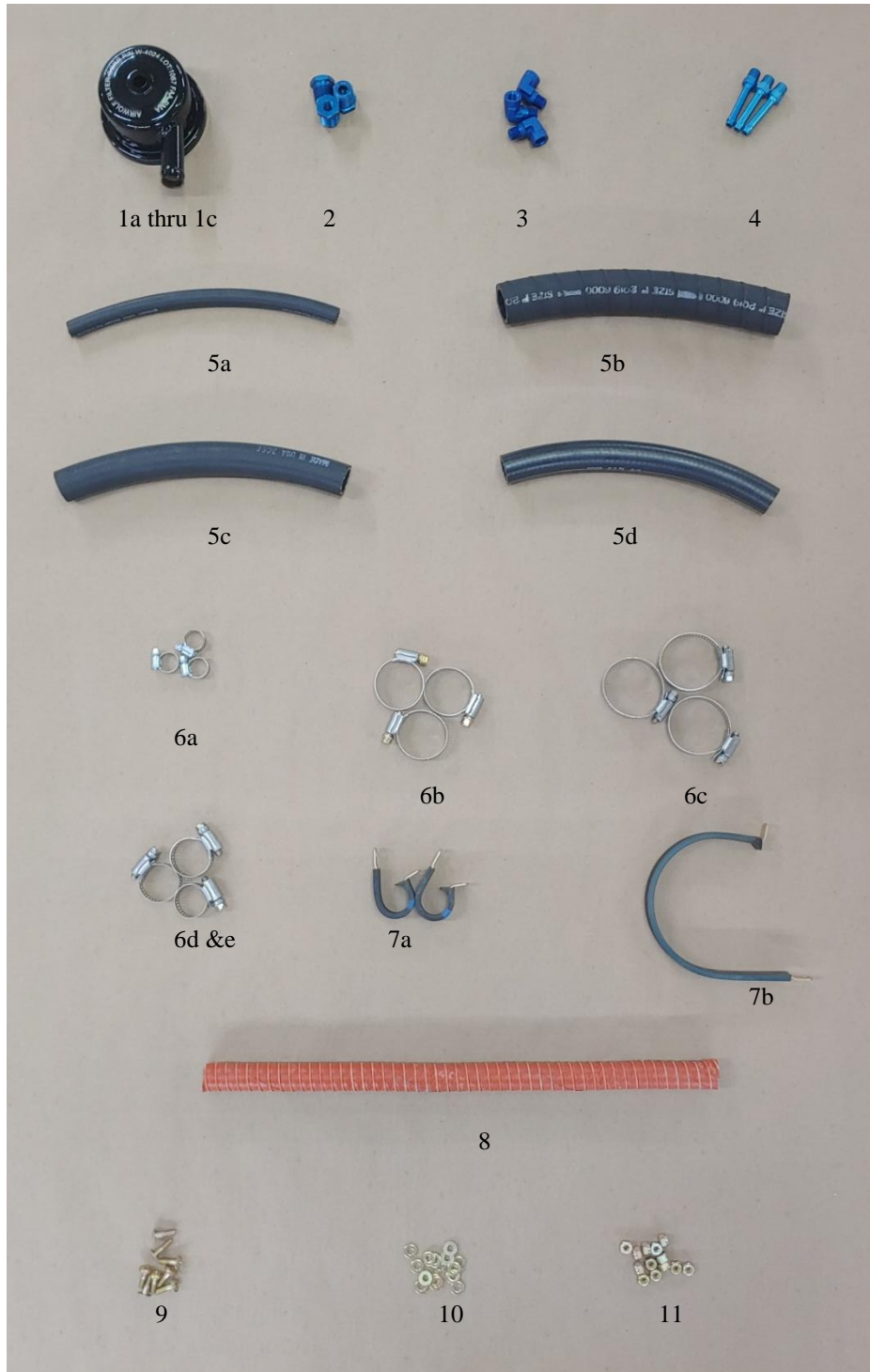

Figure 4

Applicability: Typical Mini Sep Parts Required to Install on Aircraft Engine Breather line or Wet Vacuum Pumps.

AirSep Parts List

<u>Index</u>	<u>Part Number</u>	<u>Description</u>	<u>Used with MiniSep</u>	<u>Quantity</u>
1a.	W-4000-A	MiniSep Assy, 1" Inlet - For Engine Breather		(1)
1b.	W-4000-B	MiniSep Assy, 3/4" Inlet - For Engine Breather		(1)
1c.	W-4000-C	MiniSep Assy, 5/8" Inlet - For Engine Breather		(1)
2.	AN912-3D	3/8"-1/8" NPT Reducer Bushing	ALL	(1)
3.	AN914-1D	90° Fitting, 1/8" Elbow	ALL	(1)
4.	AN840-4D	Straight Fitting, 1/8" Hose Nipple	ALL	(1)
5a.	Hose - 1/4"	Airwolf 1/4" I.D. Hose	ALL	(24")
5b.	Hose - 1"	Airwolf 1" I.D. Hose	ALL	(18")
5c.	Hose - 3/4"	Airwolf 3/4" I.D. Hose	ALL	(18")
5d.	Hose - 5/8"	Airwolf 5/8" I.D. Hose	ALL	(18")
6a.	MM-4	1/4" I.D. Hose Clamp	ALL	(2)
6b.	QS100M16H	1" I.D. Hose Clamp	ALL	(2)
6c.	QS100M12H	3/4" I.D. Hose Clamp	ALL	(2)
6d.	QS100M10H	5/8" I.D. Hose Clamp	ALL	(2)
6e.	QS100M10H	5/8" I.D. Hose Clamp	ALL	(1)
7a.	MS21919WDG-14	7/8" I.D. Adel Clamp	ALL	(1)
7b.	MS21919WDG-48	3" I.D. Adel Clamp	ALL	(1)
8.	SCAT-3	3/4" I.D. Duct	ALL	(18")
9.	AN525-10R10	#10 Screw, 5/8 Long	ALL	(2)
10.	AN960-10	#10 Washer,	ALL	(4)
11.	MS20365-1032A	#10 Locknut,	ALL	(2)

AIRWOLF AIRSEP INSTRUCTIONS FOR CONTINUED AIRWORTHINESS (ICA)

A/C Make: _____

Model: _____

Serial#: _____

N#: _____



This Instructions for Continued Airworthiness (ICA) meets the requirements of 14 CFR Part 23 Appendix G.

Airworthiness Limitations

- 1.0 The Airworthiness Limitations Section is FAA approved and specifies maintenance required under 43.16 and 91.403 of the Federal Aviation Regulations unless an alternate program has been FAA approved.
- 2.0 An STC incorporated in a larger field approval major alteration may have an airworthiness limitation. The FAA inspector should not establish, alter, or cancel an airworthiness limitation without coordinating with the appropriate FAA Type Certificate Holding Office.

Section	Description
1	Introduction: The Airwolf AirSep system is a passive oil recovery system. There are no moving parts within the AirSep.
2	Description: The AirSep is a device through which the process of coalescence, allows the oil that is normally expelled out the engine breather tube into the atmosphere, to be collected within the device for recovery at which time it is then returned back into the engine for reuse.
3	Servicing information: N/A
4	Maintenance Instructions: Clean inside of AirSep and oil return line to engine with Stoddard Solvent, Mineral Spirits or other suitable solvent, at each annual or 100 hr. inspection. In the event of a vacuum pump failure, disassemble Air/Oil Separator, thoroughly clean it and all lines, hoses and fittings and remove any traces of vacuum pump debris. Reassemble and lightly torque top nut only enough to prevent top and bottom can from rotating and center gasket to seal to prevent any leakage.
5	Trouble shooting information: If any oil is seeping out of center seam of AirSep can, replace center gasket and lightly torque top nut only enough to prevent further leakage which in most cases is 12 in/lb. If breather oil is found on the belly of the aircraft, check that outlet duct is located as per the above installation instructions and is not located in or near the high velocity airstream.
6	Removal and replacement information: Refer to the above Approved Installation Instructions for the AirSep kit.
7	Diagrams: N/A
8	Special inspection requirements: None
9	Application of protective treatments: N/A
10	List of special tools: N/A
11	Recommended overhaul periods: N/A
12	Revision: The latest revision of this ICA can be found at www.airwolf.com