



# AIRWOLF FILTER CORP.

15369 Madison Rd.

Middlefield, Ohio 44062-8404 U.S.A.

USA-1-(440) 632-5139 / (440) 632-1685 Fax

<http://www.airwolf.com> / Email: [support@airwolf.com](mailto:support@airwolf.com)



## READ THIS BEFORE INSTALLING AIR/OIL SEPARATOR DATA PERTINENT TO ALL INSTALLATIONS

### 1. REVIEW ALL INSTALLATION DATA AND WRITTEN MATERIAL BEFORE BEGINNING

2. There is **no reason** to open the Airwolf Air/Oil Separator before it is installed on the aircraft. It has been carefully assembled and tested at the factory. If you find it necessary to reclock the top or bottom of the airsep for your installation, loosen the 5/16" locknut on the top of the airsep, adjust the inlets or outlets to the proper angles and retighten the top of the airsep to 10 in/lbs. In the event of a dry vacuum pump failure, the Air/Oil Separator and all related fittings and hoses should be cleaned, inspected, or replaced as necessary.
3. **Do not** overtighten the large band clamp that holds the Air/Oil Sep to the universal mount. This can distort the shape of the can, causing oil to seep out at the seam. The Air/Oil Sep clamp is wrapped with a piece of rubber material for protection.
4. It is **EXTREMELY** important that the 1/4" & 5/16" oil return lines and lines from the vacuum pump have good gravity flow with **NO** low spots.
5. The installed Air/Oil Sep weighs an average of 24 oz. Please subtract for any items removed from the aircraft.
6. The placement of the 1-3/4" outlet duct is **VERY IMPORTANT** to the proper operation to the Airwolf Air/Oil Separator. The rules for placement are follows:
  - A. The velocity of the air passing the end of the duct, **cannot** exceed the velocity of the air exiting the end of the tube, or a syphon effect will occur.
  - B. The Air/Oil Sep is pressurized by the air discharged from the vacuum pump. This blows the fumes out through the bottom of the Air/Oil Sep, therefore there is **no need** for high velocity slipstream air to siphon fumes out of the Air/Oil Sep. If you fail to heed this advice and allow the 1-3/4" duct to stick into the high velocity slip stream, the air/oil stream exiting the crankcase breather tube will not have proper time to coalesce inside the Air/Oil Sep and this oil laden air **will** discharge onto the belly of the aircraft, creating the same problem that the Air/Oil Sep was thoroughly designed to stop. ***Trust us, we know what we're talking about.***
  - C. On aircraft with cowl flaps, the 1-3/4" outlet ducting should be approximately 6" above the cowl flap area, and 3" to 4" on either side of the cowl flap centerline.
  - D. On **ALL** installations, it normally takes 2-3 flights and 4-5 hrs of aircraft operation to properly adjust the position of the 1-3/4" outlet ducting to achieve perfection. **BE PATIENT!!!** Take your time and you will see the clean results of your effort. The Airwolf Air/Oil Separator is up to 94% effective in separating the oil from the blow-by gasses and when properly tuned, will keep the bottom of the aircraft very clean.

Thank you for taking the time to read this.  
Airwolf Filter Corp.

**This STC provides for the installation of the Airwolf AirSep™ and Airwolf MiniSep™ kit.**

**The AirSep™** assy is 4" Dia. X 6" Tall and has two inlets at the top. One inlet connects to the engine breather line, and one inlet connects to a vacuum pump [wet or dry] or an alternate source of hot air such as upper cylinder deck air.

**The MiniSep™** assy is 3" Dia. X 4" Tall and has a single inlet at the top which connects either to an engine breather line, or to the exhaust of a wet vacuum pump.

**For both AirSep™ and MiniSep™ installations:**

1.) Select the best installation location for your application [Option 1, 2, or 3 below] and follow the instructions for that installation. (See typical installations Pages 2-13)

This installation may be performed using one of the three different options for mounting the AirSep™ or MiniSep™ assy.

- 1) Engine Baffle [EB] [See Pages 4 - 6]
- 2) Engine Mount [EM] [See Pages 7 - 9]
- 3) Firewall Mount [FW] [See Pages 10 - 13]

2.) Select the appropriate AirSep or MiniSep assy part number from Pages 14-17 by matching the existing size of the engine breather line [normally 5/8, 3/4", 1" or 1-1/4" O.D.] to the same size inlet on the AirSep or MiniSep assy.

**For AirSeps:** Decide which 1/2" or 5/8" fitting "clock angle" on the AirSep assy provides the best hose routing to the vacuum pump or engine baffle through hole, whichever is chosen for the source of hot air.

3.) Select the appropriate oil return method from Pages 18 - 21 to return the recovered oil to the engine sump.

Note: The drain on the AirSep or MiniSep can be relocked to give the shortest, simplest route to the engine by loosening the top nut. Simply twist the bottom of the AirSep or Mini Sep to get the correct clocking and then retighten the top nut to 12 in/lbs.

4.) Simply fill out a FAA Form 337 by checking Option "EB", "EM", or "FW", etc. On the back of Form 337, detail all parts used in the particular aircraft installation (See pages 22-25). Note hose type, size and lengths used for each hose (for future easy replacement) and any additional information that may be pertinent to your installation.

5.) Attach a copy of the ICA (See page 26) and Form 337 to logbook or file in engine maintenance records.

**NOTE:** If you develop any useful installation hints or practices that may be useful, please contact: Airwolf Filter Corp, 15369 Madison Rd, Middlefield, OH 44062. (800) 326-1534 , (440) 632-5136 or support@airwolf.com. We are always interested in improving our products and services to our customers.

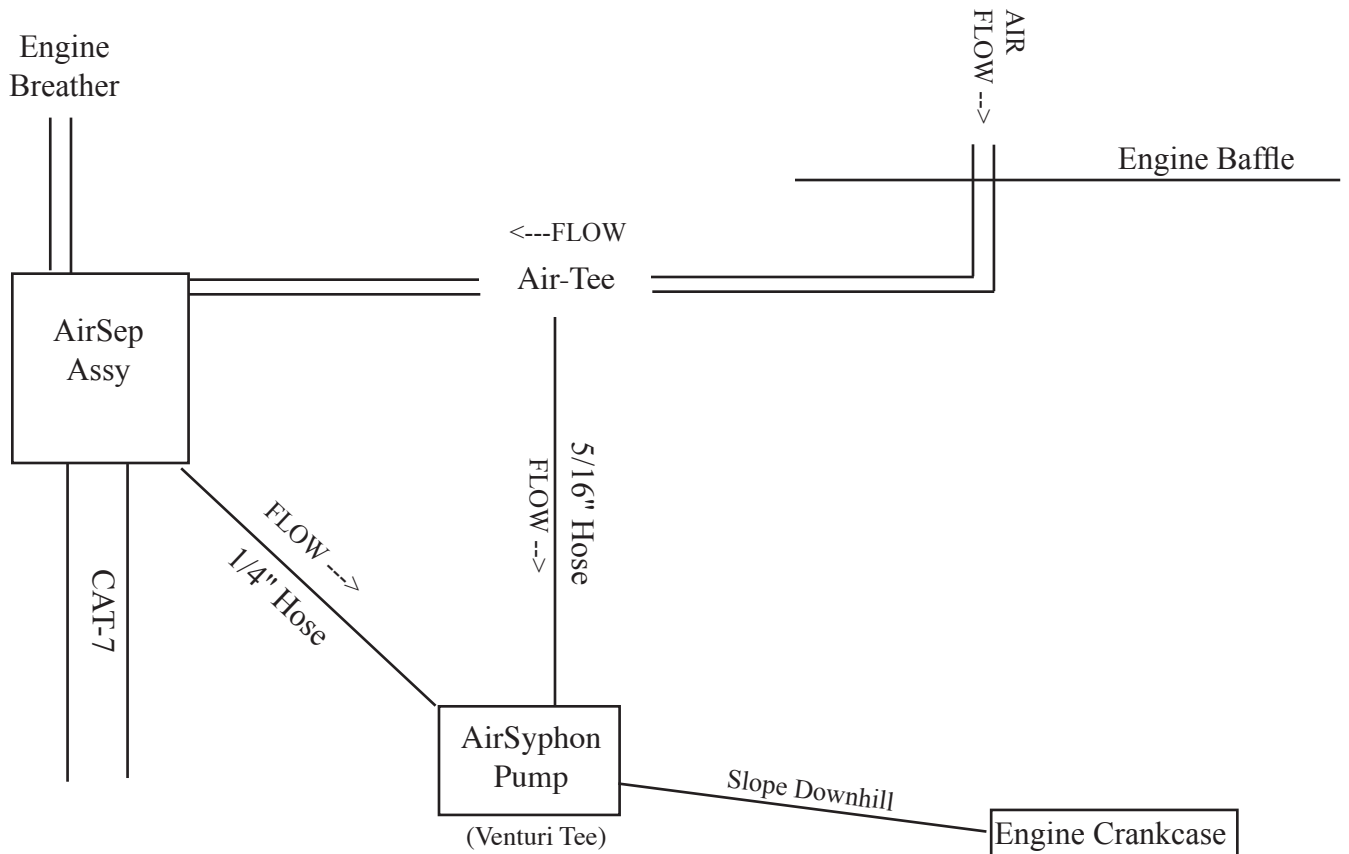
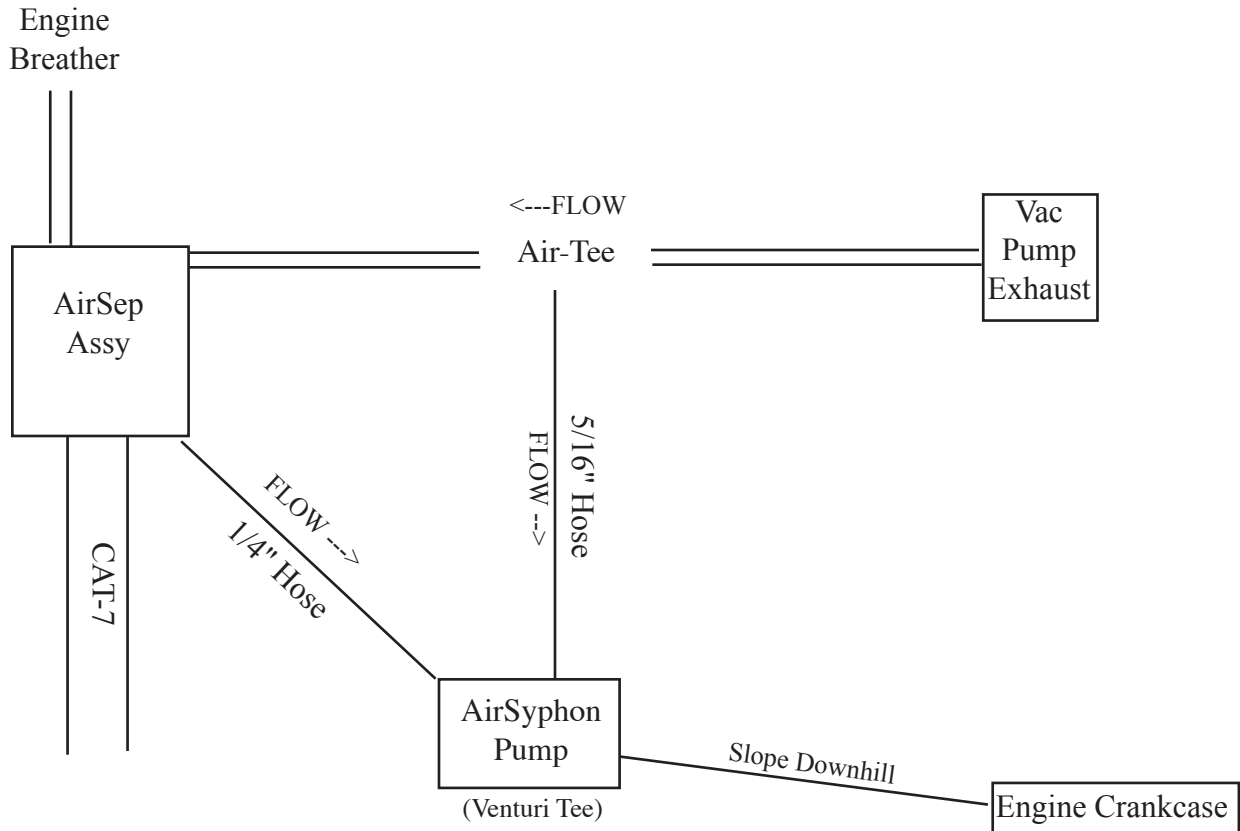

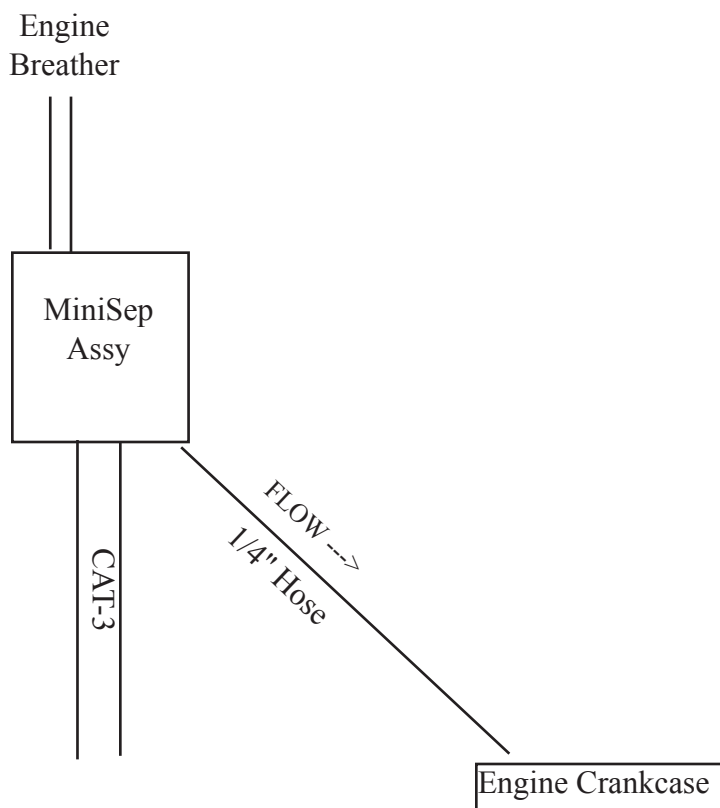
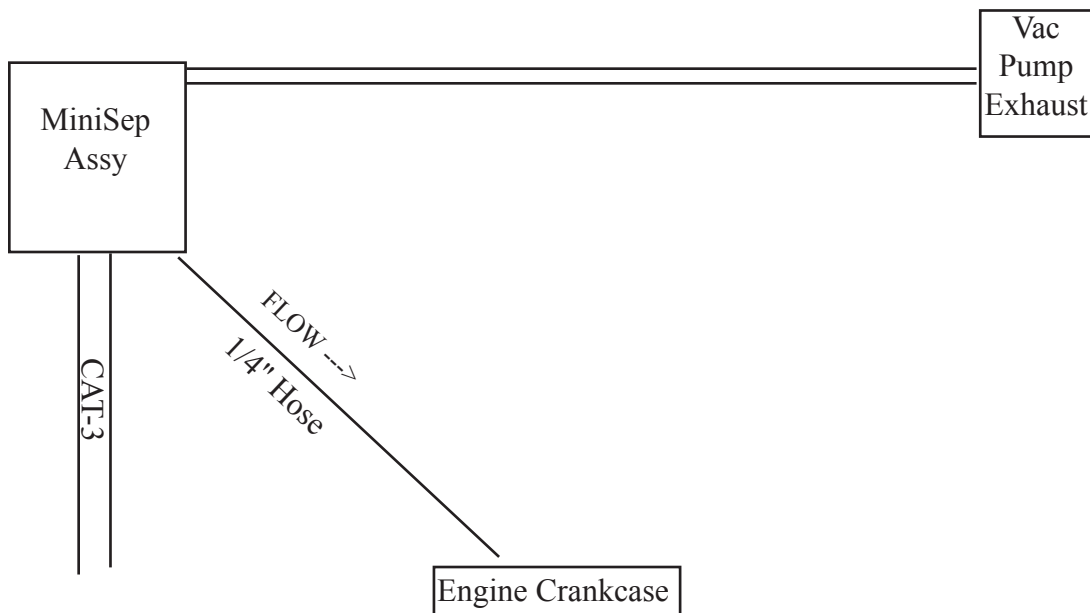

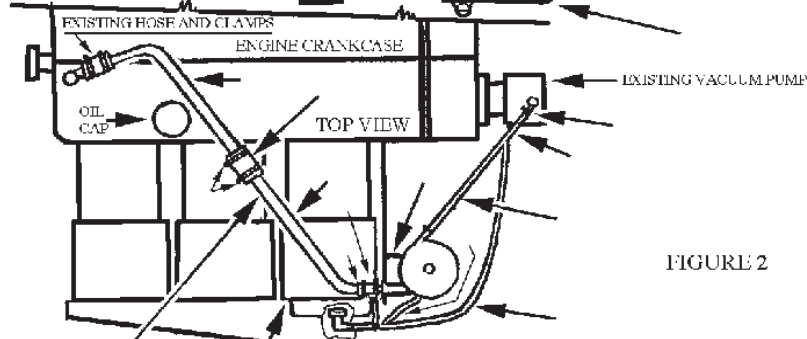
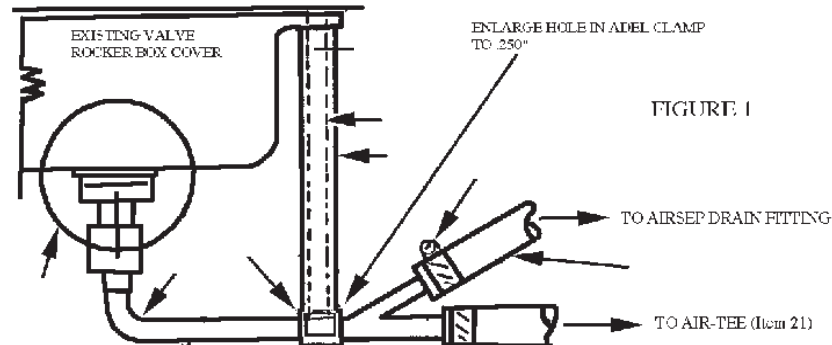
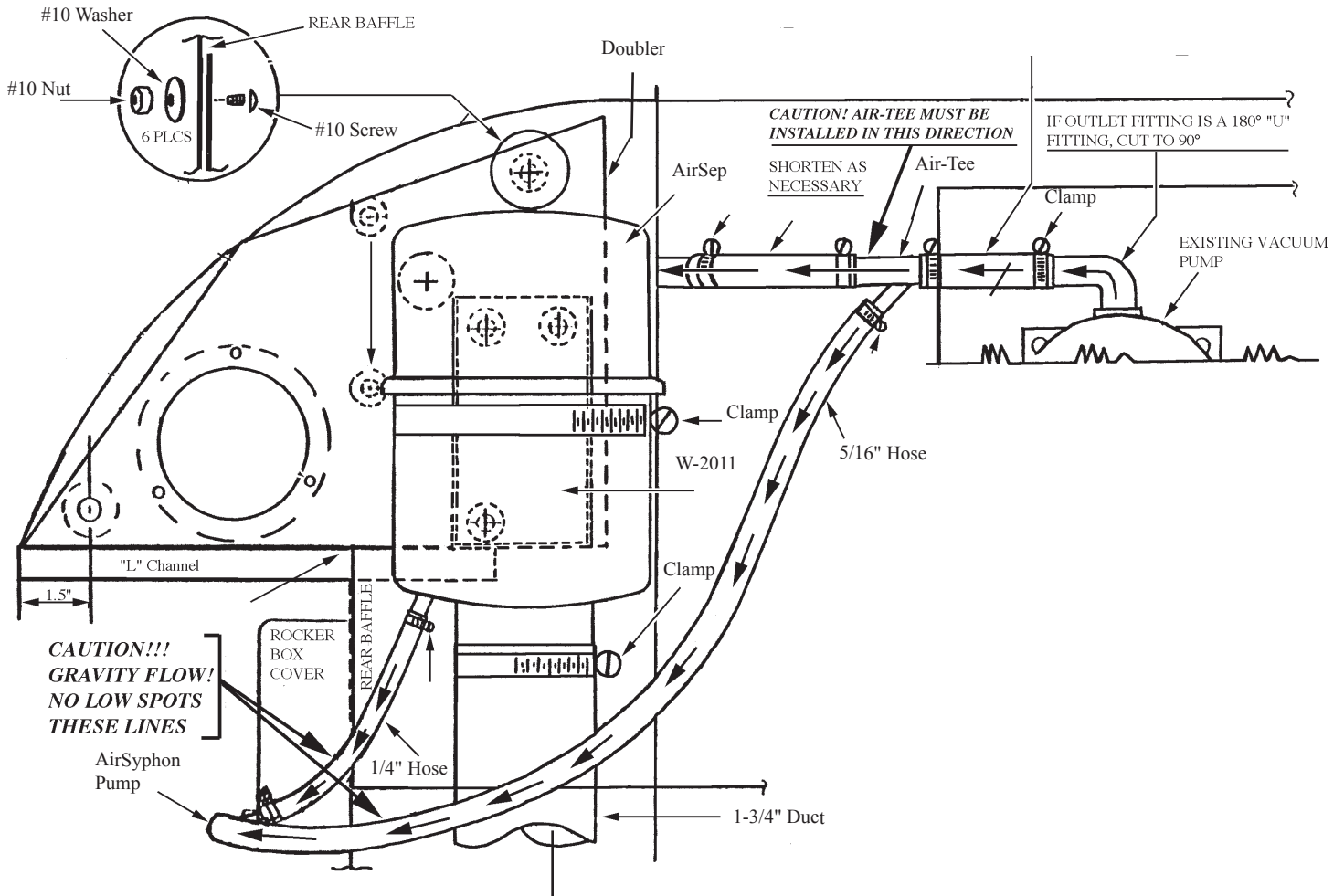

REINSTALL WEATHER SLEEVING IF PREVIOUSLY INSTALLED  
SEE ABOVE FOR DETAILS  
NOTES:  
MODIFY ENGINE ROCKER BOX COVER I/A/W FAA APPROVED ROCKER BOX RETURN FITTING KIT P/N KW-2031

Note A: *Some hoses or wires may have to be rerouted so the air/oil separator will fit into position.  
Reference and material per AC 43.13-1B & 2A.*

**WARNING: ALL HOSES SHALL BE LOCATED AT LEAST 4.0" FROM ANY HEAT SOURCE LIKELY TO CAUSE VAPORIZATION OF THE OIL.**

01. Gain access to engine compartment.
  02. Using the W-2011 bracket at a template, center the bracket on the LH or RH rear engine baffle and drill four 3/16" holes.
  03. Mount the W-2011 bracket on the engine baffle, using the W-2150 doubler positioned on the fwd side of the engine baffle and loosely hold in place with 4 ea #10 screws, washers and locknuts.
  04. Slide the 4-1/2" clamp between the W-2011 bracket and the engine baffle to be used to hold the AirSep.
  05. Tighten the four #10 screws installed in step #3 at this time.
  06. Mount AirSep to W-2011 bracket and tighten the 4-1/2" clamp.. Note: Bottom drain line of the AirSep must be positioned so that it is above the level of the entrance to the engine. Oil must be able to drain downhill.
- NOTE: If the bottom drain is not "clocked" correctly for the aircraft, loosen the top 5/16-24 Nut. Then, holding the can top, twist the can bottom to get the correct orientation to provide the simplest flow to the engine. Then retighten the nut to no more than 12 in/lbs.
07. Using a piece of MIL6000 hose, connect the inlet of AirSep to existing engine breather line and secure with QS100 clamps.
  - 08a. If no vacuum pump installed on the aircraft, drill a 5/8" hole into the engine baffle. Run a short piece of 5/8" MIL6000 hose from the hole in the baffle to the Air-Tee, and from the Air-Tee to the 5/8" inlet on the AirSep to gain hot ram air from top of cyls.  
Note: Make sure the word "Flow" on the Air-Tee is pointing towards the AirSep.
  - 08b. If a vacuum pump is installed on the aircraft, use a piece of MIL6000 hose to connect the 5/8" exhaust fitting on the vacuum pump to the Air-Tee, and from the Air-Tee to the 5/8" inlet on the AirSep to gain hot vacuum pump exhaust  
Note: Make sure the word "Flow" on the Air-Tee is pointing towards the AirSep.
  09. Determine the method of returning the recovered oil in the AirSep, to the engine. Connect an Air Syphon pump to the engine, I/A/W the schematic shown on page 9.
  10. Connect the 5/16" branch of the Air Syphon Pump the 5/16" branch of the Air-Tee.
  11. Connect the 1/4" branch of the Air Syphon Pump the 1/4" drain on the AirSep.
  12. Connect a length of CAT-7 hose to the bottom of the AirSep and secure with a 1-3/4" clamp.
  13. Secure the CAT-7 hose to an engine mount, firewall or structure using a -30 Adel Clamp.  
NOTE: Do not allow the CAT-7 hose to extend out the bottom of the engine cowl. If you fail to heed this advice and allow the 1-3/4" duct to stick into the high velocity slip stream, the air/oil stream exiting the crankcase breather tube will not have proper time to coalesce inside the Air/Oil Sep and this oil laden air will discharge onto the belly of the aircraft, creating the same problem that the Air/Oil Sep was thoroughly designed to stop.
  14. Determine weight & balance, initiate Form 337, and update the equipment list.



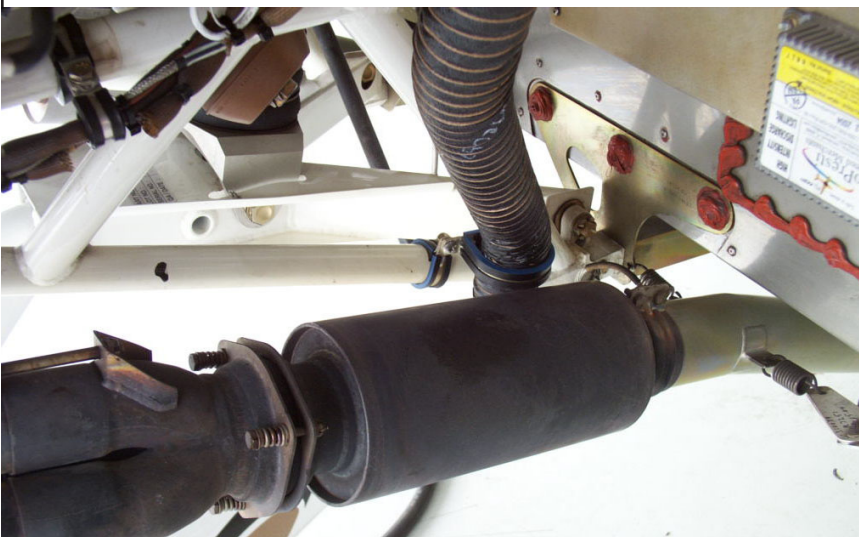
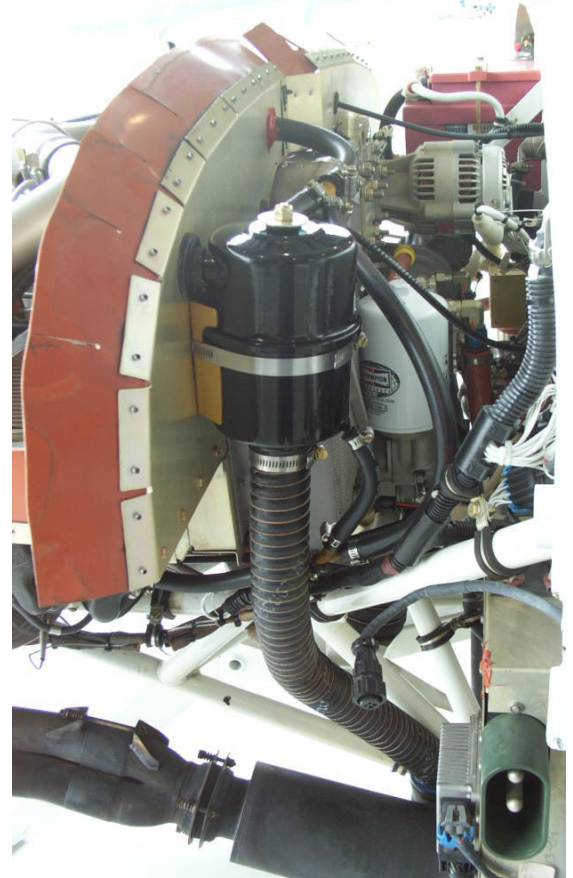
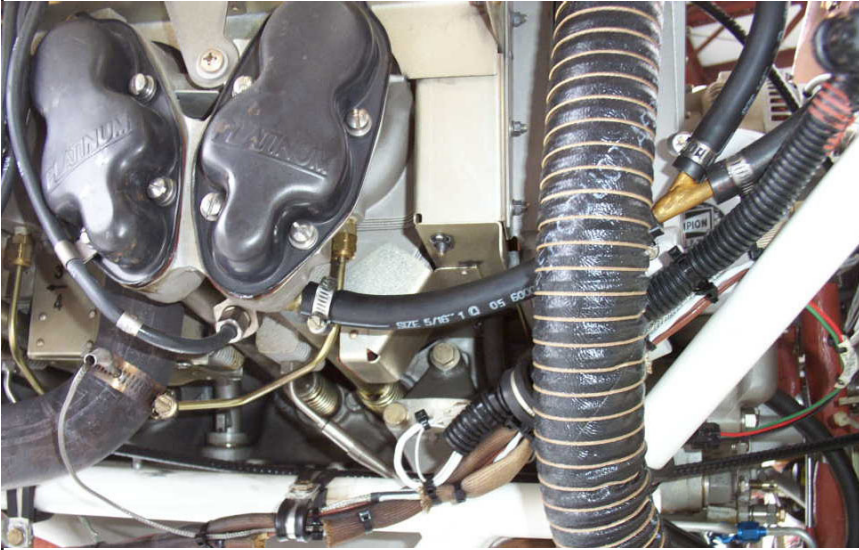

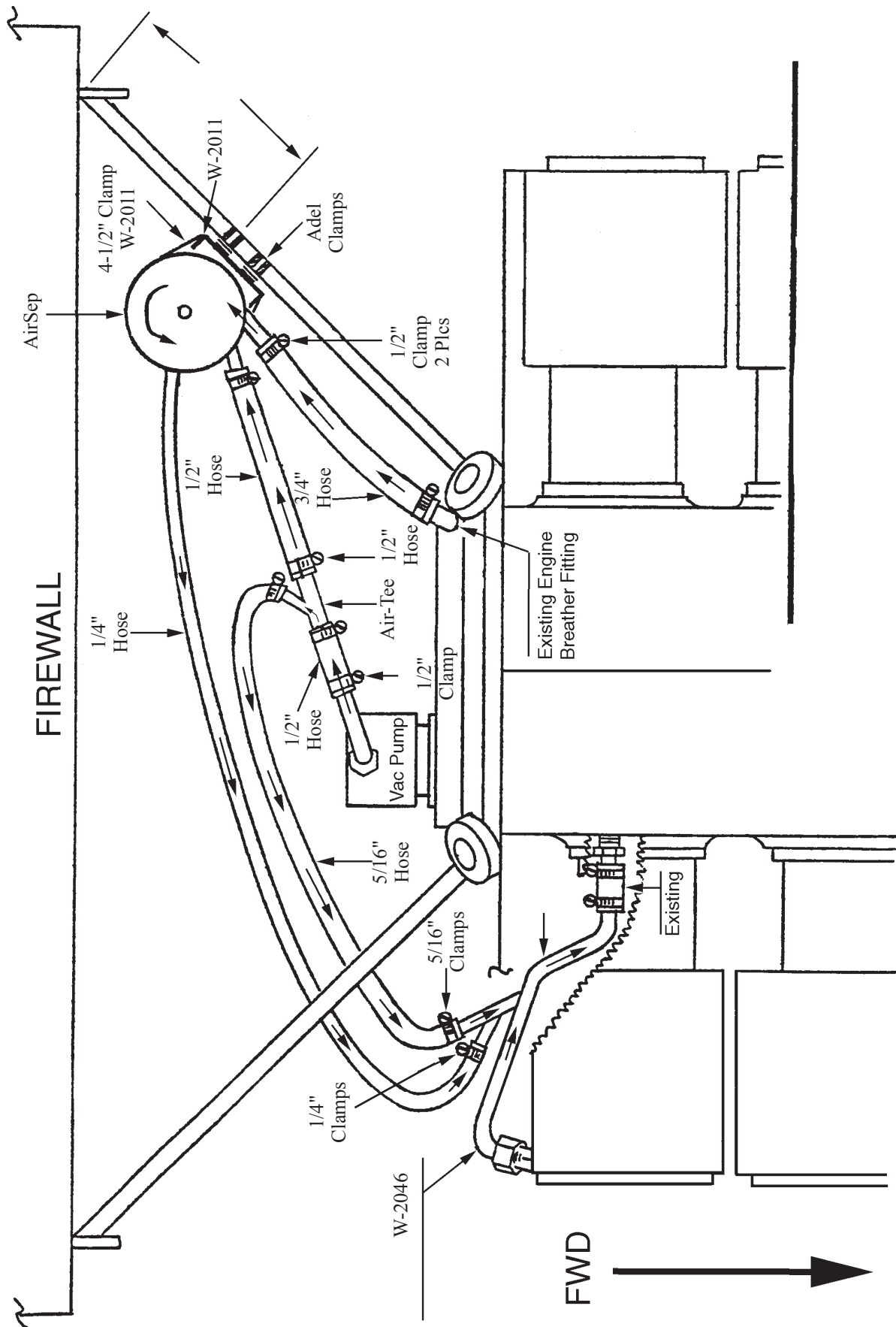



Note A: Some hoses or wires may have to be rerouted so the air/oil separator will fit into position.  
Reference and material per AC 43.13-1B & 2A.

**WARNING: ALL HOSES SHALL BE LOCATED AT LEAST 4.0" FROM ANY HEAT SOURCE LIKELY TO CAUSE VAPORIZATION OF THE OIL.**

01. Gain access to engine compartment.
02. Secure a mounting bracket, to the engine mount with appropriate adel clamps and standard hardware..
03. Attach the W-2011 bracket on the previously installed mounting bracket with 4 ea #10 screws, washers and locknuts.
04. Slide the 4-1/2" clamp between the W-2011 bracket and the mounting bracket to be used to hold the AirSep.
05. Tighten the four #10 screws installed in step #3 at this time.
06. Mount AirSep to W-2011 bracket and tighten the 4-1/2" clamp.. Note: Bottom drain line of the AirSep must be positioned so that it is above the level of the entrance to the engine. Oil must be able to drain downhill.

NOTE: If the bottom drain is not "clocked" correctly for the aircraft, loosen the top 5/16-24 Nut. Then, holding the can top, twist the can bottom to get the correct orientation to provide the simplest flow to the engine. Then retighten the nut to no more than 12 in/lbs.

07. Using a piece of MIL6000 hose, connect the inlet of AirSep to existing engine breather line and secure with QS100 clamps.
- 08a. If no vacuum pump installed on the aircraft, drill a 5/8" hole into the engine baffle. Run a short piece of 5/8" MIL6000 hose from the hole in the baffle to the Air-Tee, and from the Air-Tee to the 5/8" inlet on the AirSep to gain hot ram air from top of cyls.  
Note: Make sure the word "Flow" on the Air-Tee is pointing towards the AirSep.
- 08b. If a vacuum pump is installed on the aircraft, use a piece of MIL6000 hose to connect the 5/8" exhaust fitting on the vacuum pump to the Air-Tee, and from the Air-Tee to the 5/8" inlet on the AirSep to gain hot vacuum pump exhaust

**Note: Make sure the word "Flow" on the Air-Tee is pointing towards the AirSep.**

09. Determine the method of returning the recovered oil in the AirSep, to the engine. Connect an Air Syphon pump to the engine I/A/W the schematic shown on page 9.
10. Connect the 5/16" branch of the Air Syphon Pump the the 5/16" branch of the Air-Tee
11. Connect the 1/4" branch of the Air Syphon Pump the the 1/4" draing on the AirSep.
12. Connect a length of CAT-7 hose to the bottom of the AirSep and secure with a 1-3/4" clamp.
13. Secure the CAT-7 hose to an engine mount, firewall or structure using a -30 Adel Clamp.

NOTE: Do not allow the CAT-7 hose to extend out the bottom of the engine cowl. If you fail to heed this advice and allow the 1-3/4" duct to stick into the high velocity slip stream, the air/oil stream exiting the crankcase breather tube will not have proper time to coalesce inside the Air/Oil Sep and this oil laden air **will** discharge onto the belly of the aircraft, creating the same problem that the Air/Oil Sep was thoroughly designed to stop.

14. Determine weight & balance, initiate Form 337, and update the equipment list.

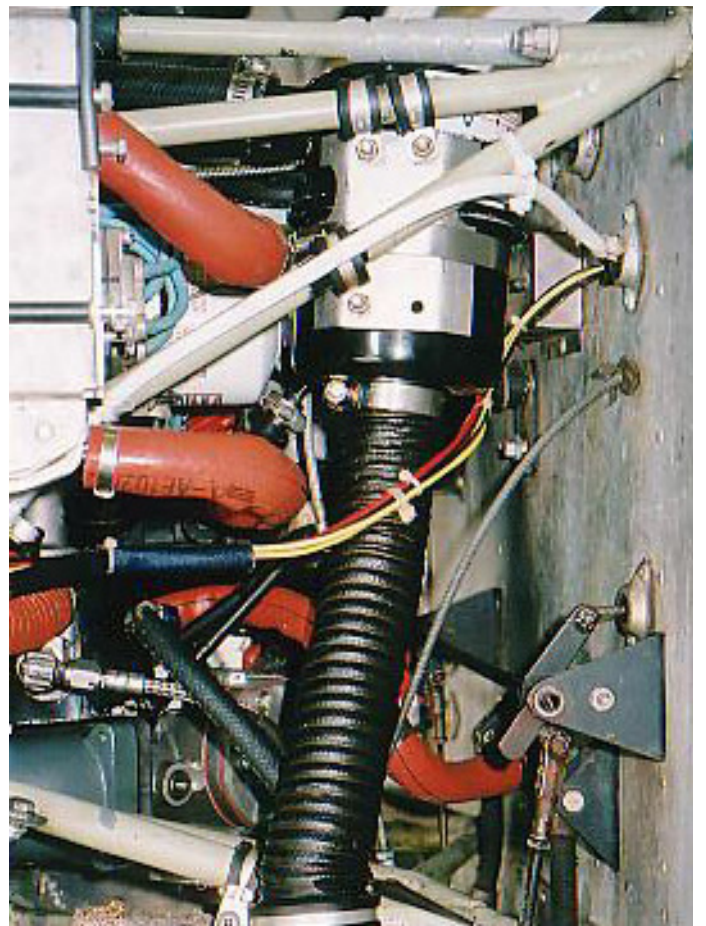
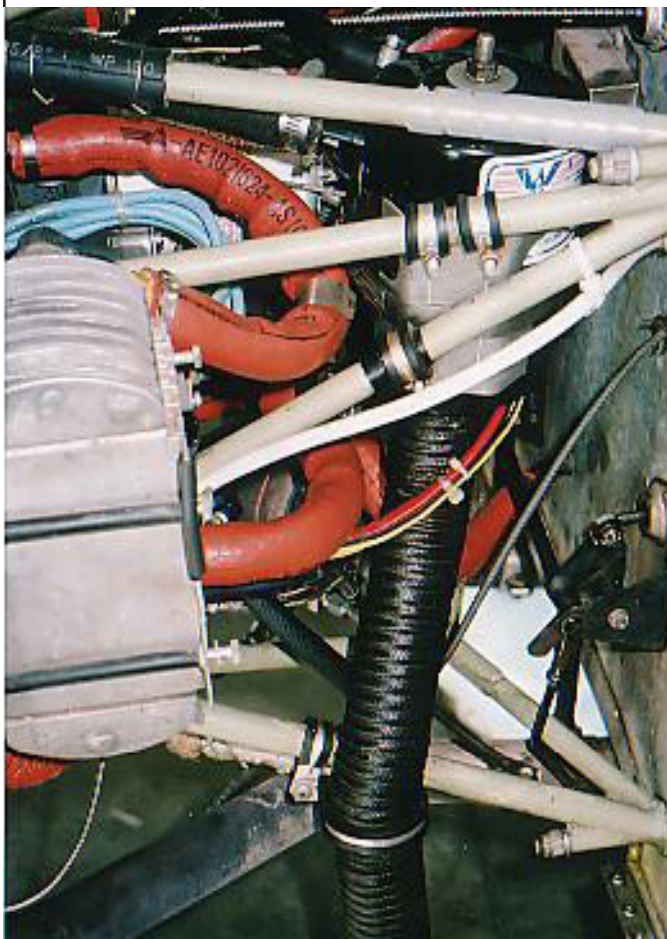



Drawing: AFC-W360  
 Revision: C  
 Date: 08/24/06

**TYPICAL FIREWALL MOUNTED AIRSEPS INSTALLATION  
 SHOWN ON CESSNA U206**

Applicability:

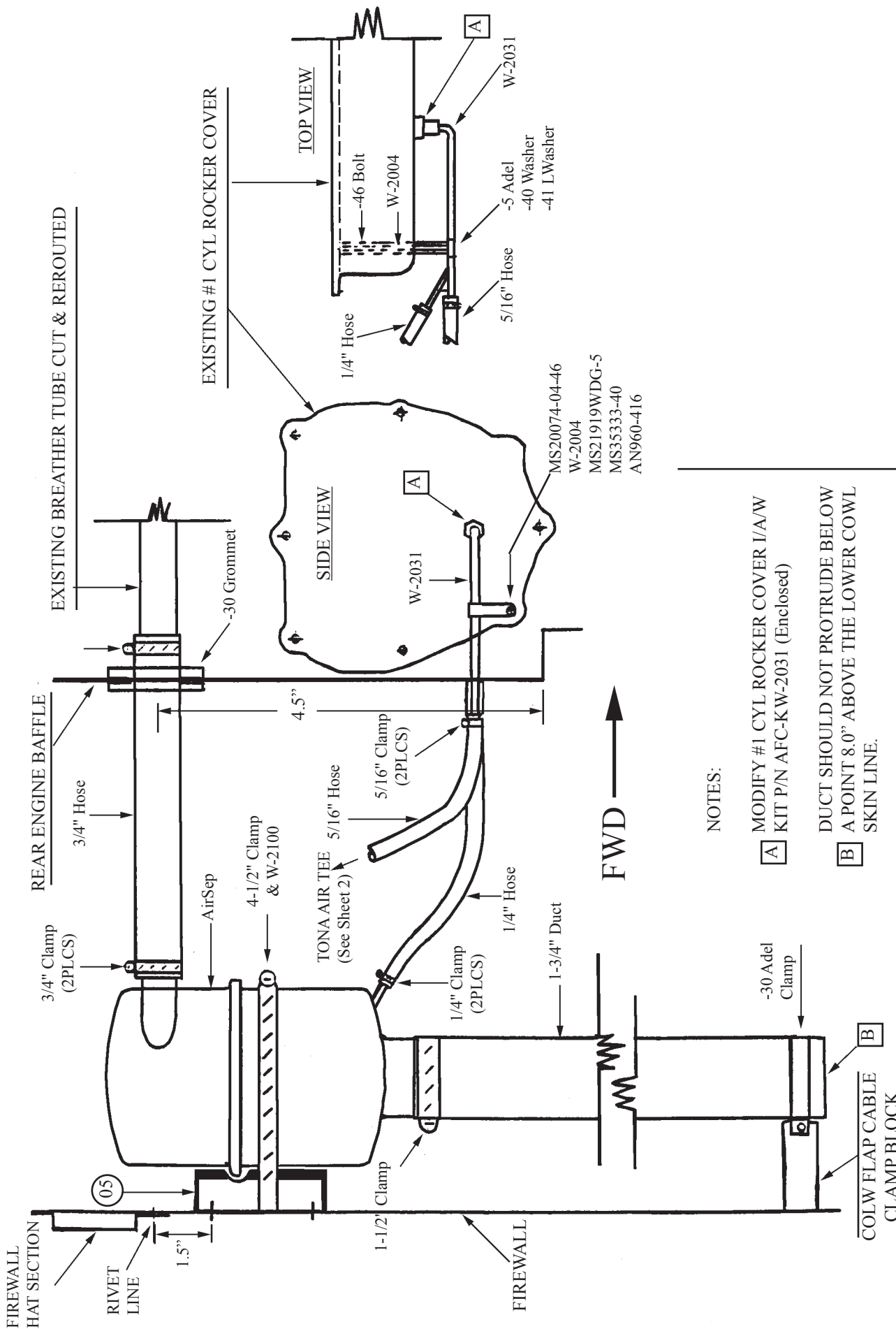

NOTES:

- A** MODIFY #1 CYL ROCKER COVER I/A/W KIT P/N AFC-K-W-2031 (Enclosed)
- B** DUCT SHOULD NOT PROTRUDE BELOW A POINT 8.0" ABOVE THE LOWER COWL SKIN LINE.

*Note A: Some hoses or wires may have to be rerouted so the air/oil separator will fit into position.  
Reference and material per AC 43.13-1B & 2A.*

**WARNING: ALL HOSES SHALL BE LOCATED AT LEAST 4.0" FROM ANY HEAT SOURCE LIKELY TO CAUSE VAPORIZATION OF THE OIL.**

01. Gain access to engine compartment.
  02. Using the W-2011 bracket at a template, center the bracket on the LH or RH side firewall and drill four 3/16" holes.
  03. Mount the W-2011 bracket on the firewall, using the W-2150 doubler positioned on the aft side of the firewall and loosely hold in place with 4 ea #10 screws, washers and locknuts.
  04. Slide the 4-1/2" clamp between the W-2011 bracket and the firewall to be used to hold the AirSep.
  05. Tighten the four #10 screws installed in step #3 at this time.
  06. Mount AirSep to W-2011 bracket and tighten the 4-1/2" clamp.. Note: Bottom drain line of the AirSep must be positioned so that it is above the level of the entrance to the engine. Oil must be able to drain downhill.
- NOTE: If the bottom drain is not "clocked" correctly for the aircraft, loosen the top 5/16-24 Nut. Then, holding the can top, twist the can bottom to get the correct orientation to provide the simplest flow to the engine. Then retighten the nut to no more than 12 in/lbs.
07. Using a piece of MIL6000 hose, connect the inlet of AirSep to existing engine breather line and secure with QS100 clamps.
  - 08a. If no vacuum pump installed on the aircraft, drill a 5/8" hole into the engine baffle. Run a short piece of 5/8" MIL6000 hose from the hole in the baffle to the Air-Tee, and from the Air-Tee to the 5/8" inlet on the AirSep to gain hot ram air from top of cyls.  
Note: Make sure the word "Flow" on the Air-Tee is pointing towards the AirSep.
  - 08b. If a vacuum pump is installed on the aircraft, use a piece of MIL6000 hose to connect the 5/8" exhaust fitting on the vacuum pump to the Air-Tee, and from the Air-Tee to the 5/8" inlet on the AirSep to gain hot vacuum pump exhaust  
Note: Make sure the word "Flow" on the Air-Tee is pointing towards the AirSep.
  09. Determine the method of returning the recovered oil in the AirSep, to the engine. Connect an Air Syphon pump to the engine I/A/W the schematic shown on page 9.
  10. Connect the 5/16" branch of the Air Syphon Pump the 5/16" branch of the Air-Tee
  11. Connect the 1/4" branch of the Air Syphon Pump the 1/4" drain on the AirSep.
  12. Connect a length of CAT-7 hose to the bottom of the AirSep and secure with a 1-3/4" clamp.
  13. Secure the CAT-7 hose to an engine mount, firewall or structure using a -30 Adel Clamp.  
NOTE: Do not allow the CAT-7 hose to extend out the bottom of the engine cowl. If you fail to heed this advice and allow the 1-3/4" duct to stick into the high velocity slip stream, the air/oil stream exiting the crankcase breather tube will not have proper time to coalesce inside the Air/Oil Sep and this oil laden air will discharge onto the belly of the aircraft, creating the same problem that the Air/Oil Sep was thoroughly designed to stop.
  14. Determine weight & balance, initiate Form 337, and update the equipment list.



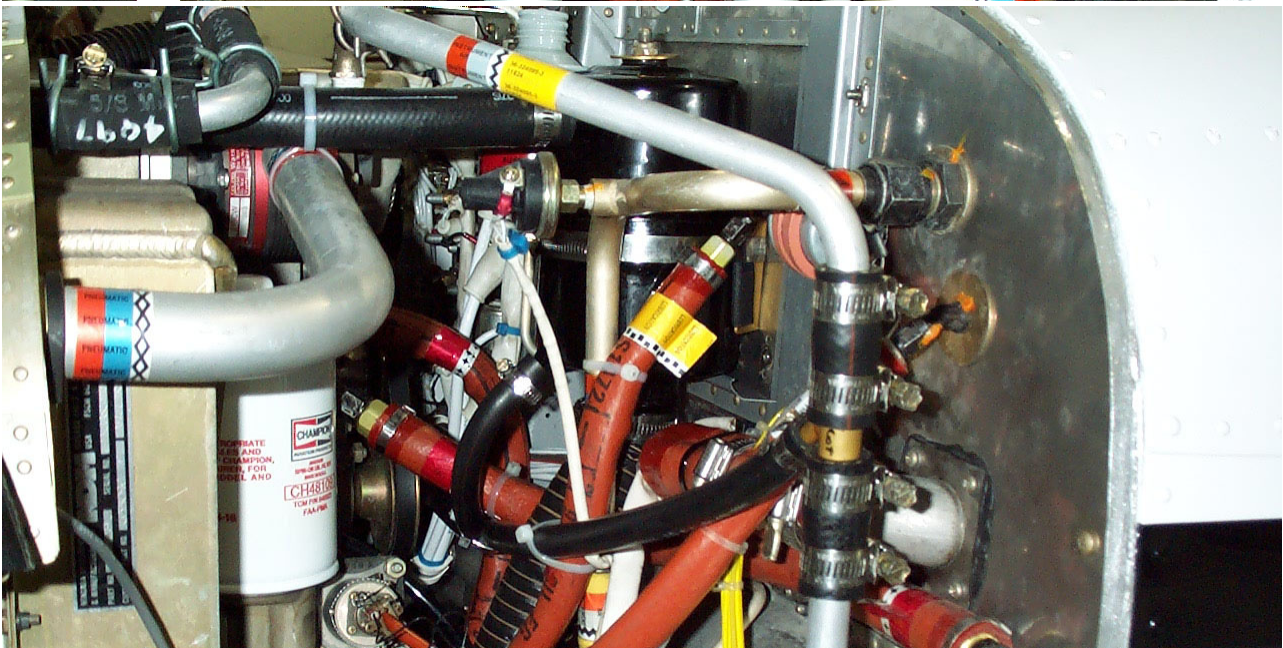
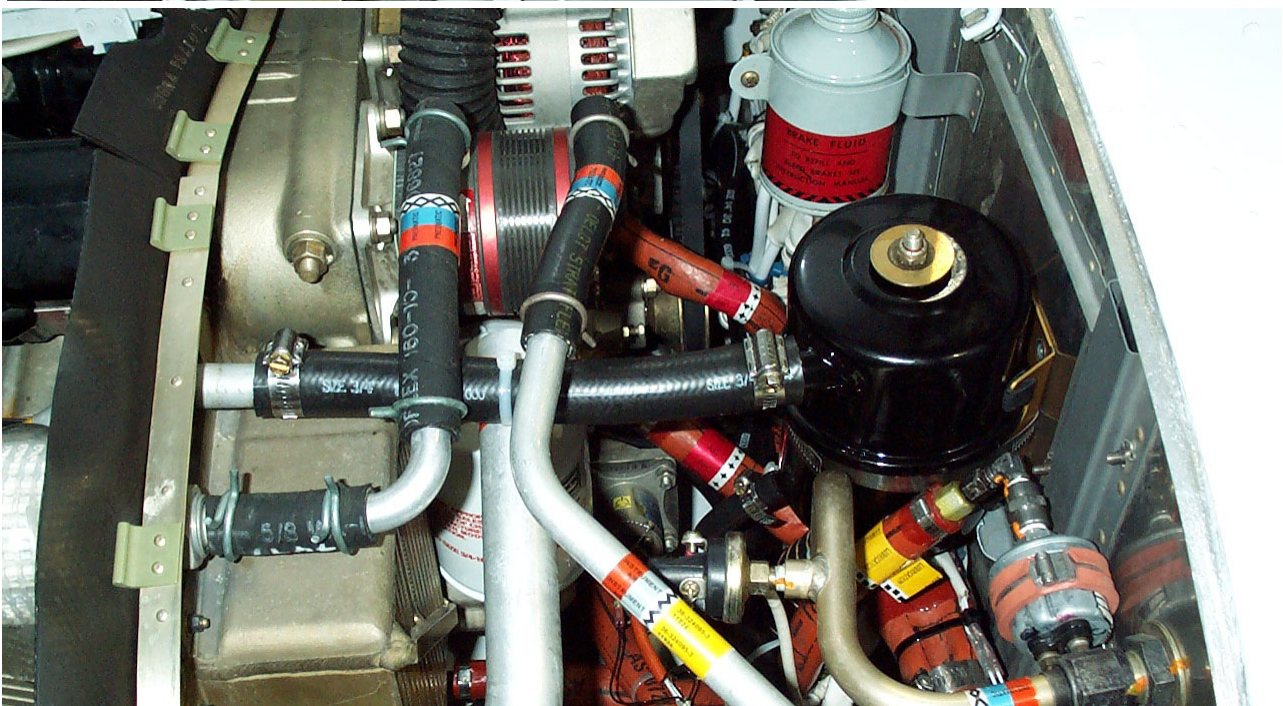



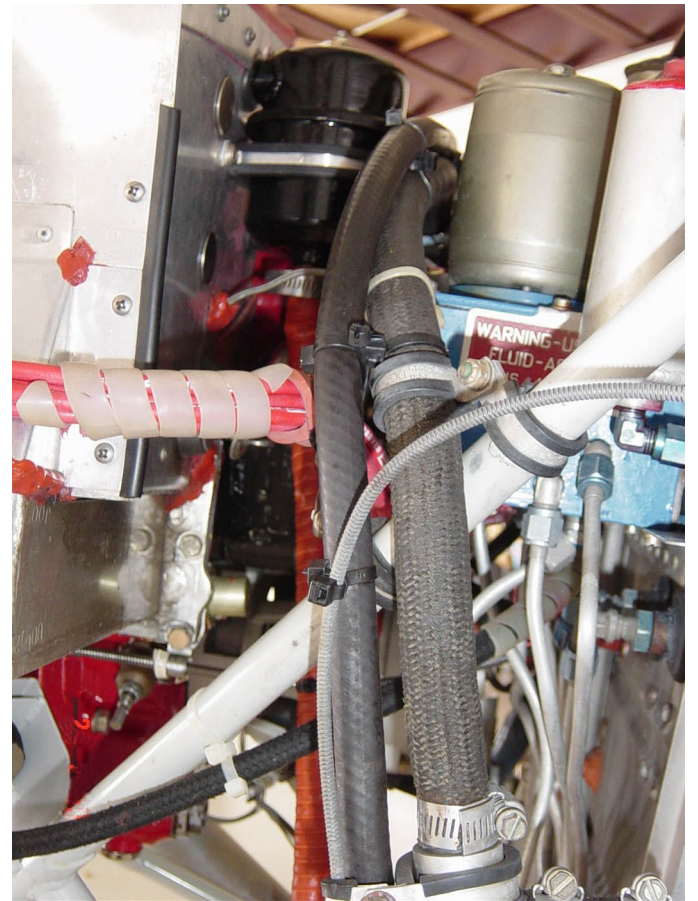
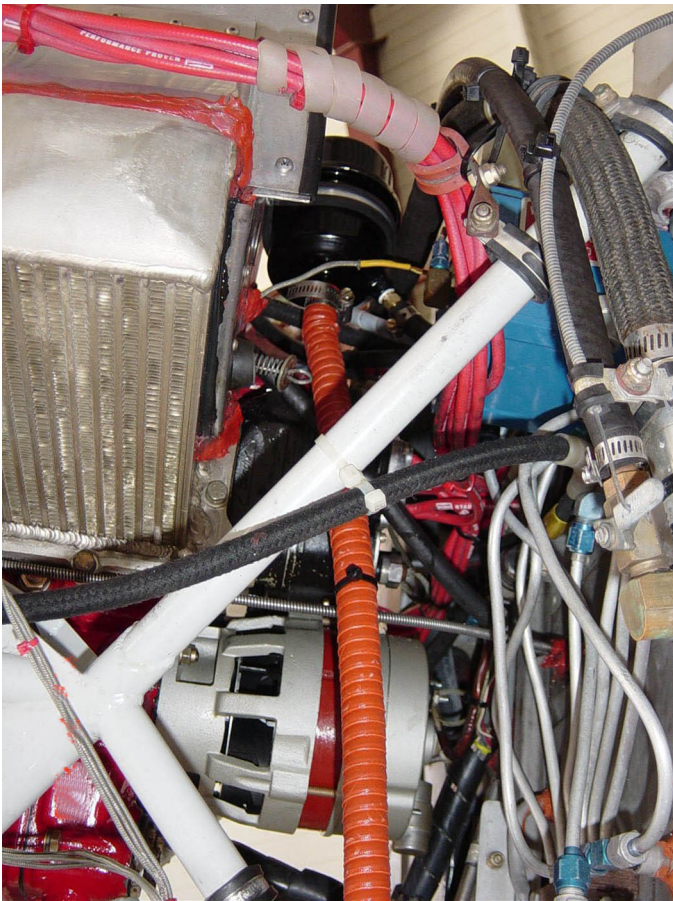

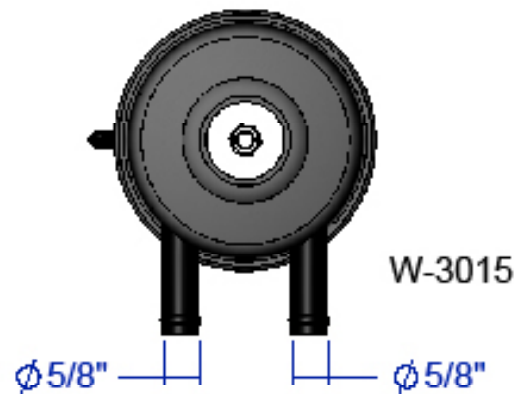
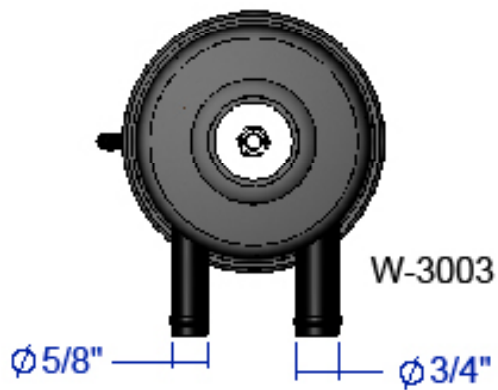
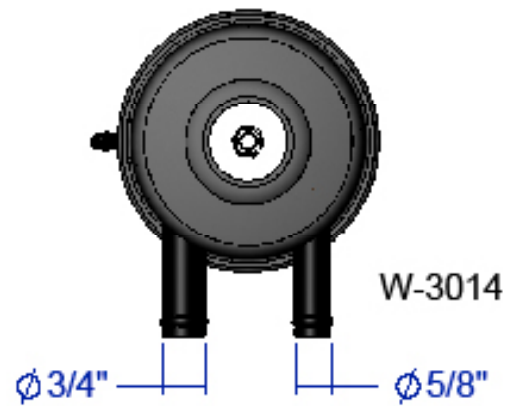
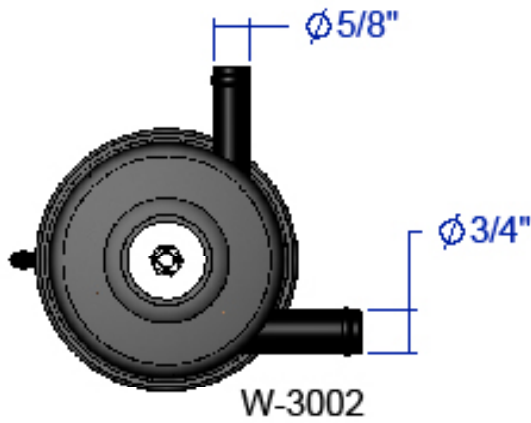
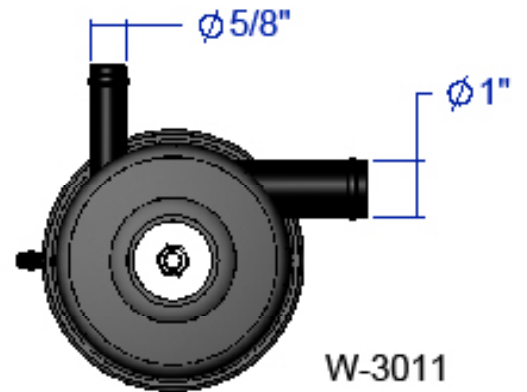
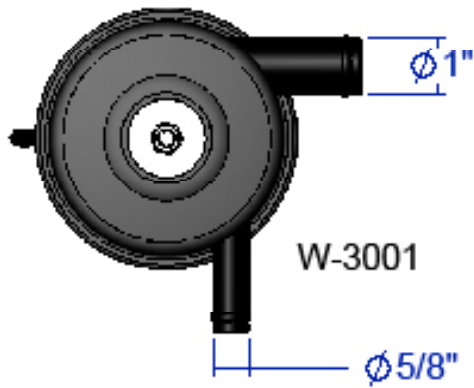
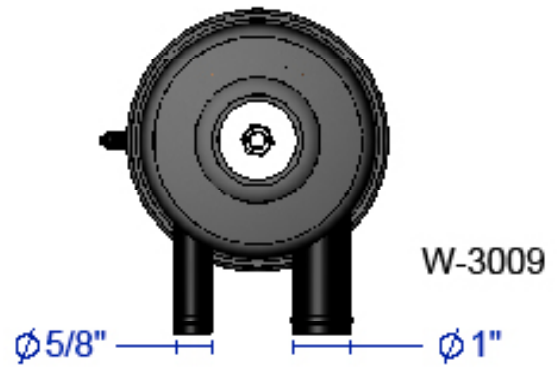
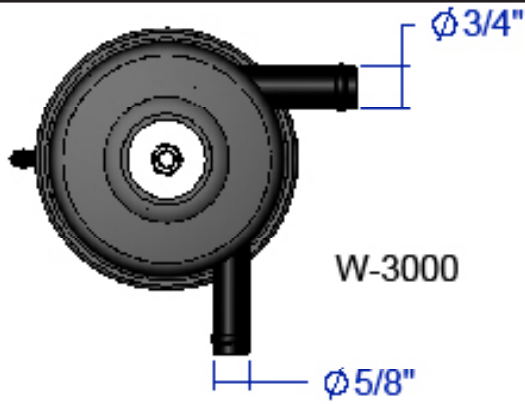

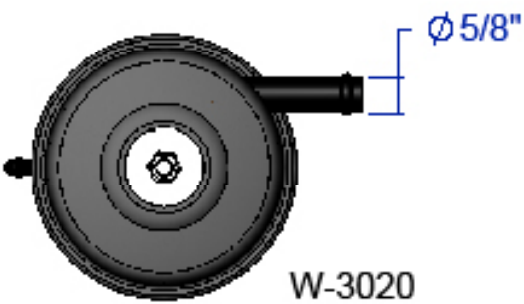
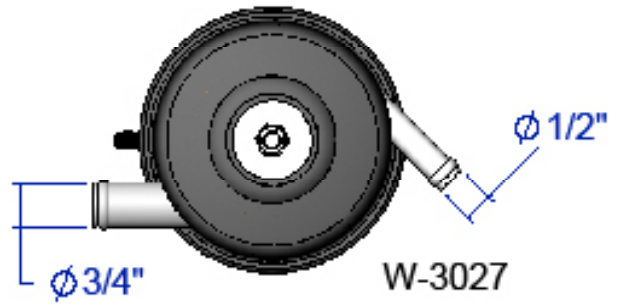
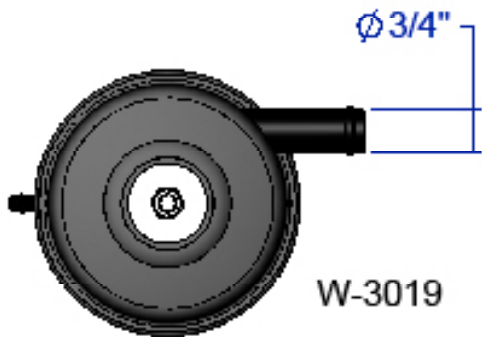
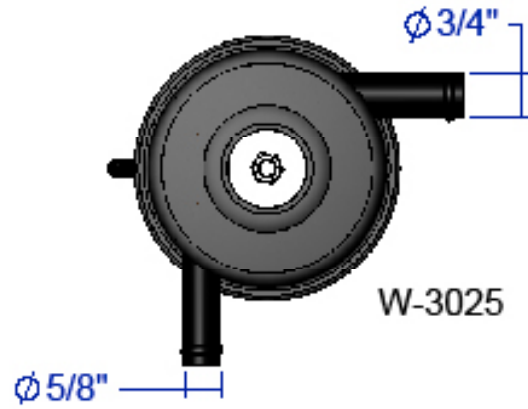
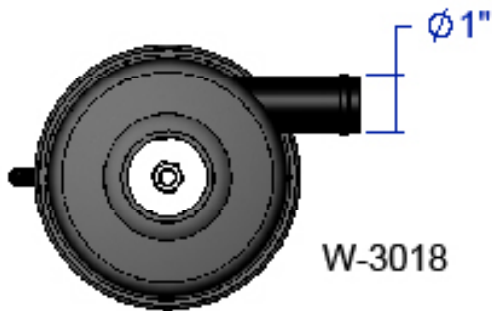
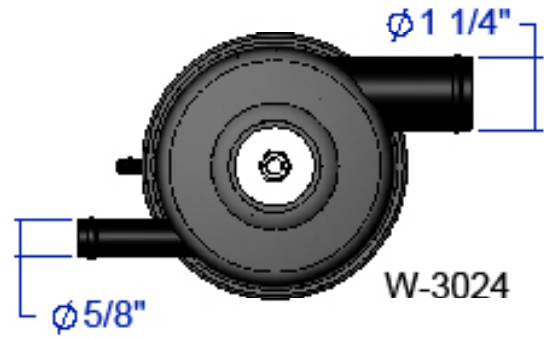
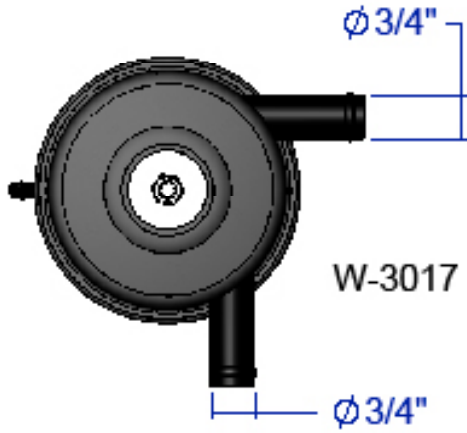



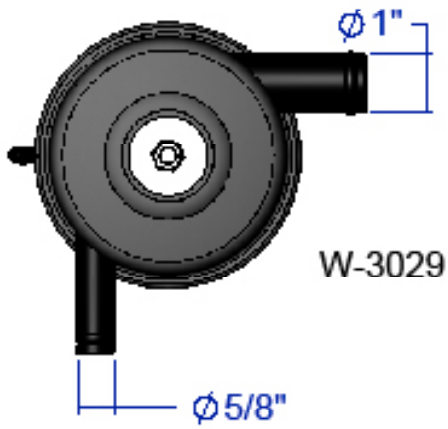

W-3029

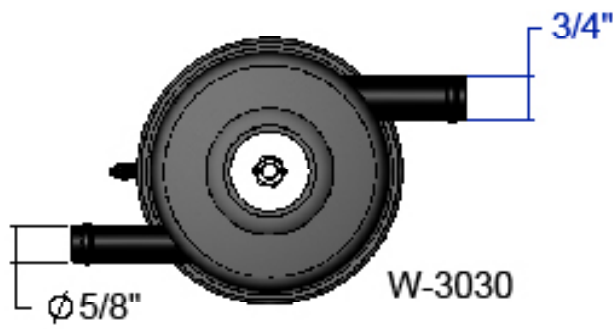

W-3030

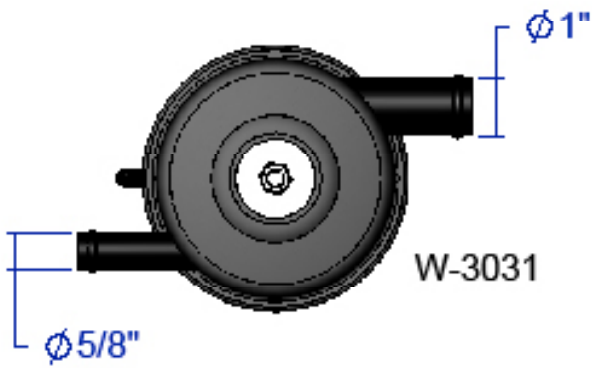

W-3031

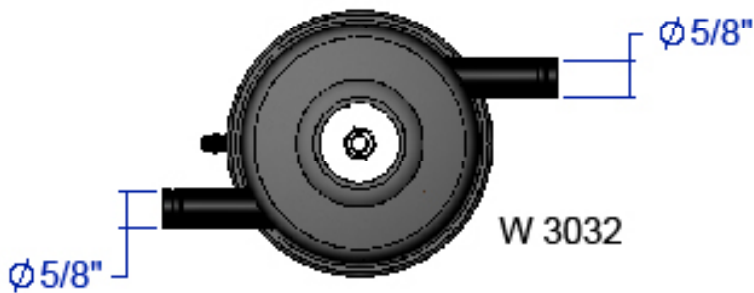

W 3032

USE ON ENGINE BREATHERS

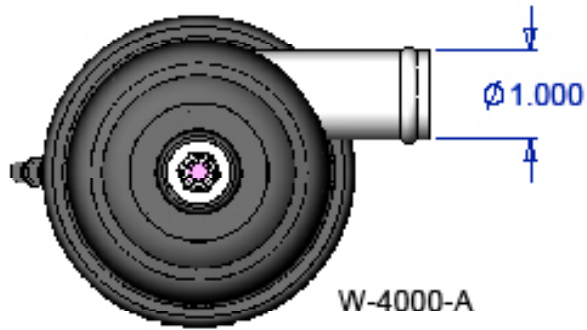

W-4000-A

USE ON WET VACUUM PUMPS

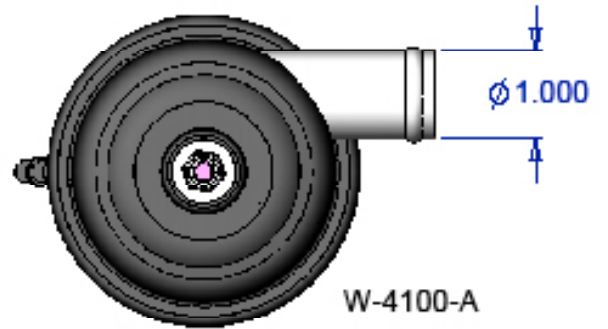

W-4100-A

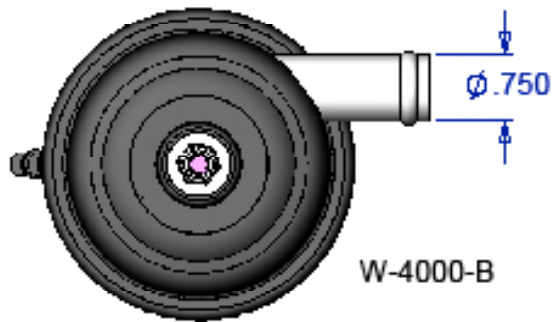

W-4000-B

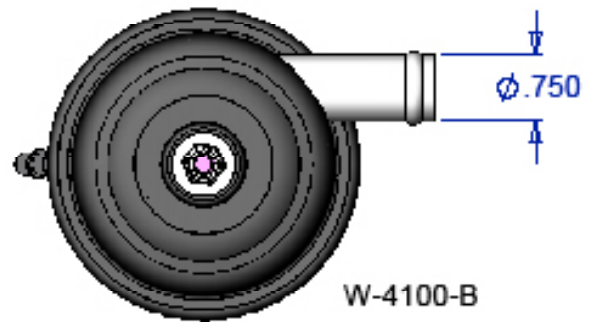

W-4100-B

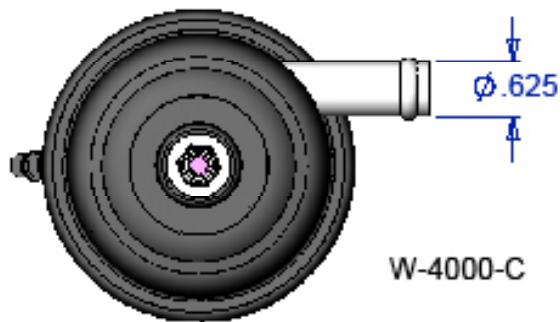

W-4000-C

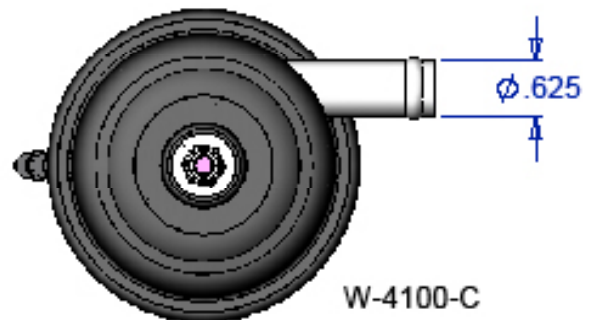

W-4100-C



**FOR AIRSEPT™**

<u>P/N</u>	<u>DESCRIPTION</u>	<u>ENGINE</u>	
KW-2031	Rocker Cover Mod	TCM Engines TCM IO470-D/E/F/G/H/L/LO/P/R/S/T/U/V/VO & LIO470-A TCM TSIO470-B/C/D TCM IO520-A/B/BA/C/D/E/F/J/K/L/M TCM O470-B/G/H/K/L/M/N/P/R/S/T/U TCM O470-B-CI/G-CI/K-CI/L-CI/M-CI TCM IO470-A/C TCM TSIO520-A/B/C/D/E/F/G/H/J/K/L/M/N/P/R	[STC# SE92WE] [STC# SE93WE] [STC# SE94WE] [STC# SE95WE] [STC# SE95WE] [STC# SE95WE] [STC# SE96WE]
W-2008	AirSyphon Pump	Lyc O235-O540 Series and TCM A65-IO550 series	
W-2014	AirSyphon Pump	All Engines using Pushrod Shroud Tube Option	
W-2031	AirSyphon Pump	Lyc O235-O540 Series and TCM IO470-D/E/F/G/H/L/LO/P/R/S/T/U/V/VO & LIO470-A TCM TSIO470-B/C/D TCM IO520-A/B/BA/C/D/E/F/J/K/L/M TCM O470-B/G/H/K/L/M/N/P/R/S/T/U TCM O470-B-CI/G-CI/K-CI/L-CI/M-CI TCM IO470-A/C TCM TSIO520-A/B/C/D/E/F/G/H/J/K/L/M/N/P/R	[STC# SE92WE] [STC# SE93WE] [STC# SE94WE] [STC# SE95WE] [STC# SE95WE] [STC# SE95WE] [STC# SE96WE]
W-2046	AirSyphon Pump	Lyc O235-O540 Series, #3 or #5 Cyl Drain	
W-2046-1	AirSyphon Pump	Lyc O320-H series engines with 1/2" Cyl Drains	
W-2046-2	AirSyphon Pump	Lyc O235-O540 Series, #4 or #6 Cyl Drain	
W-2046-3	AirSyphon Pump	Lyc O235-O540 Series, #4 or #6 Cyl Drain	
W-2046-4	AirSyphon Pump	Lyc IO360 & IO540 Series, #3 or #5 Cyl Drain	
W-2046-5	AirSyphon Pump	Lyc IO360 & IO540 Series, #4 or #6 Cyl Drain	
W-2154-1	Pushrod Shroud Tube	TCM 470/520/550 Engines with Single Rocker Cover	
W-2154-2	Pushrod Shroud Tube	TCM 470/520/550 Engines with Single Rocker Cover	
W-2154-3	Pushrod Shroud Tube	TCM 470/520/550 Engines with Single Rocker Cover	
W-2154-4	Pushrod Shroud Tube	TCM 470/520/550 Engines with Single Rocker Cover	
W-2154-5	Pushrod Shroud Tube	TCM 470/520/550 Engines with Single Rocker Cover	
W-2155-1	Pushrod Shroud Tube	TCM IO550G/N/R/P Engines with Dual Rocker Covers	
W-2155-2	Pushrod Shroud Tube	TCM IO550G/N/R/P Engines with Dual Rocker Covers	
W-2156	Rocker Cover Mod	All Franklin Engines	

**FOR MINISEPT™**

<u>P/N</u>	<u>DESCRIPTION</u>	<u>ENGINE</u>
AN840-4D	Straight Fitting	ALL
AN842-4D	90° Fitting	ALL
AN844-4D	45° Fitting	ALL
AN912-3D	Reducer Fitting	ALL

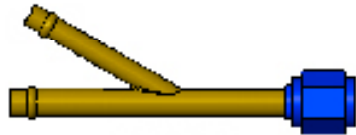

W-2008

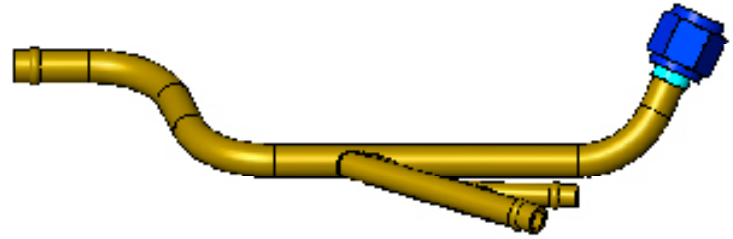

W-2046



W-2014

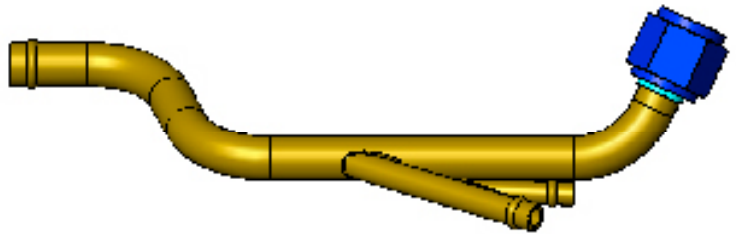

W-2046-1



W-2031



W-2046-2

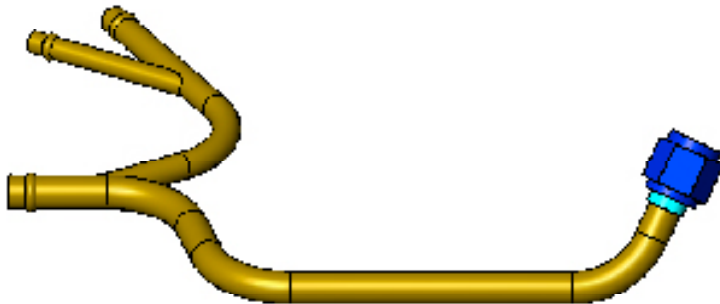

W-2046-3



W-2046-4

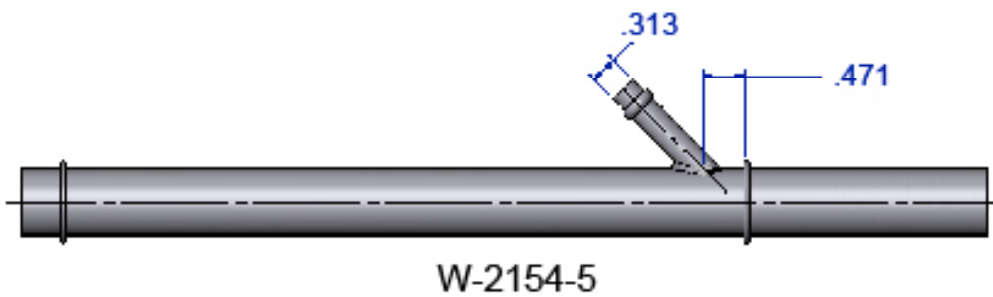
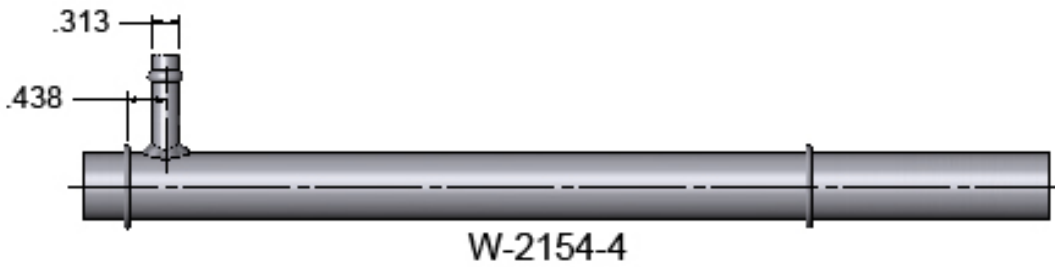
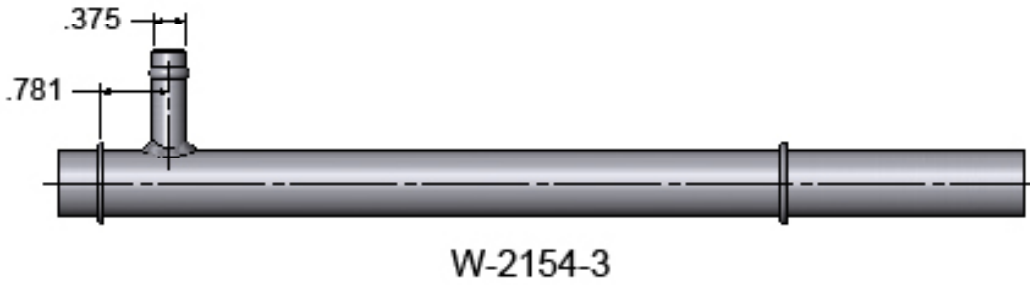
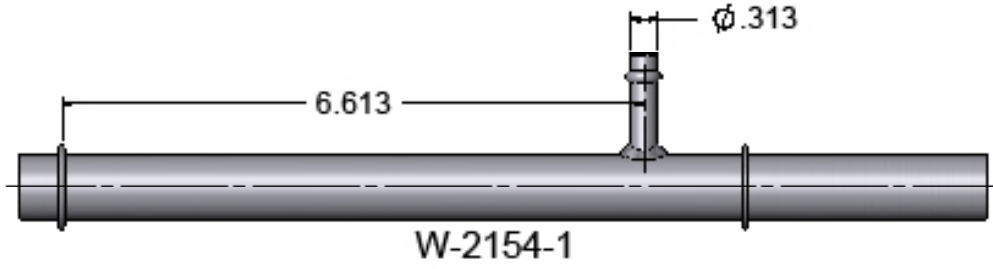

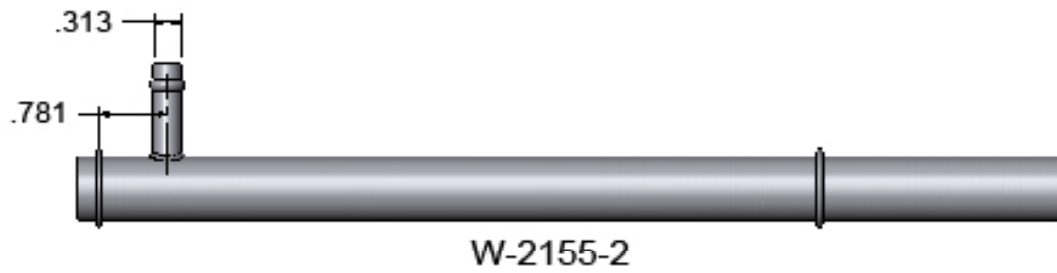
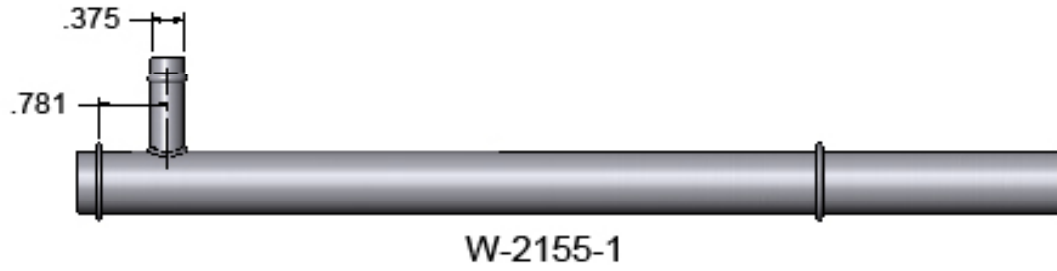

AirSep™ Parts List

<u>Index</u>	<u>Part Number</u>	<u>Description</u>	<u>Quantity</u>
01.	W-2004	Bushing	(1)
02	W-2008	AirSyphon Pump	(1)
03	W-2011	Bracket	(1)
04.	W-2014	AirSyphon Pump	(1)
05a.	W-2018	1/2" O.D. Air-Tee	(1)
05b..	W-2018-1	5/8" O.D. Air-Tee	(1)
06.	W-2021	Doubler	(1)
07a.	W-2022	Air-Tee	(1)
07b.	W-2022-1	Air-Tee	(1)
08.	W-2023	Doubler	(1)
09.	W-2024	Flange	(1)
10a.	W-2025-1	Breather Tube	(1)
10b.	W-2025-2	Breather Tube	(1)
11.	W-2027	Doubler	(1)
12a.	W-2028-1	Breather Tube	(1)
12b.	W-2028-2	Breather Tube	(1)
12c.	W-2028-3	Breather Tube	(1)
13.	W-2029	Bracket	(1)
14.	W-2030	Breather Tube	(1)
15	W-2031	AirSyphon Pump	(1)
16.	W-2032	Breather Tube	(1)
17.	W-2033	Brace	(1)
18a.	W-2034	Breather Tube	(1)
18b.	W-2034-1	Breather Tube	(1)
18c.	W-2034-2	Breather Tube	(1)
19.	W-2035	Breather Tube	(1)
20.	W-2035-1	Breather Tube	(1)
21.	W-2036	Brace	(1)
22.	W-2037	Bracket	(1)
23.	W-2038	Tee	(1)
29.	W-2039	Brace	(1)
30.	W-2040	AirSyphon Pump	(1)
31.	W-2041	Brace	(1)
32.	W-2042	Doubler	(1)
33a.	W-2043	Flange	(1)
33b.	W-2043-1	Flange	(1)
34.	W-2045	Doubler, C-172	(1)
35a.	W-2046	AirSyphon Pump	(1)
35b.	W-2046-1	AirSyphon Pump	(1)
35c.	W-2046-2	AirSyphon Pump	(1)
35d.	W-2046-3	AirSyphon Pump	(1)
36.	W-2047	Doubler, Maule	(1)
37.	W-2048	Doubler, Maule	(1)
38.	W-2100	"C" Channel	(1)
39.	W-2150	Doubler	(1)
40.	W-2151	Bracket	(1)
42.	W-2152	Air-Tee	(1)
43.	W-2153	Discharge Tube	(1)
44.	W-2154-1	Shroud Tube	(1)
44.	W-2154-2	Shroud Tube	(1)
44.	W-2154-3	Shroud Tube	(1)
44.	W-2154-4	Shroud Tube	(1)
44.	W-2154-5	Shroud Tube	(1)
45.	W-2155-1	Shroud Tube	(1)
45.	W-2155-2	Shroud Tube	(1)
46.	W-2157	Franklin Rocker Box Mod	(1)



**AirSep™ Parts List (continued)**

<u>Index</u>	<u>Part Number</u>	<u>Description</u>	<u>Quantity</u>
50	MM-4	1/4" I.D. Hose Clamp	A/R
50	MM-5	5/16" I.D. Hose Clamp	A/R
50	QS100M08H	1/2" I.D. Hose Clamp	A/R
50	QS100M10H	5/8" I.D. Hose Clamp	A/R
50	QS100M12H	3/4" I.D. Hose Clamp	A/R
50	QS100M16H	1" I.D. Hose Clamp	A/R
50	QS100M24H	1-3/4" I.D. Hose Clamp	A/R
50	QS100M72H	4-1/2" I.D. Hose Clamp	A/R
51	Hose-1/4	Airwolf 1/4" I.D. Hose	A/R
51	Hose-5/16	Airwolf 5/16" I.D. Hose	A/R
51	Hose-3/8	Airwolf 3/8" I.D. Hose	A/R
51	Hose-1/2	Airwolf 1/2" I.D. Hose	A/R
51	Hose-5/8	Airwolf 5/8" I.D. Hose	A/R
51	Hose-3/4	Airwolf 3/4" I.D. Hose	A/R
51	Hose-1	Airwolf 1" I.D. Hose	A/R
51	Hose-1-1/4	Airwolf 1-1/4" I.D. Hose	A/R

**AirSeps for Engine Breather & Wet or Dry Vacuum Pumps**

<u>P/N</u>	<u>DESCRIPTION</u>
W-3000	AirSep Assy, 1/4" Drain
W-3001	AirSep Assy, 1/4" Drain
W-3002	AirSep Assy, 1/4" Drain
W-3002-B	AirSep Assy, 3/8" Drain
W-3003	AirSep Assy, 1/4" Drain
W-3009	AirSep Assy, 1/4" Drain
W-3011	AirSep Assy, 1/4" Drain
W-3011-B	AirSep Assy, 3/8" Drain
W-3014	AirSep Assy, 1/4" Drain
W-3014-B	AirSep Assy, 3/8" Drain
W-3015	AirSep Assy, 1/4" Drain
W-3017	AirSep Assy, 1/4" Drain
W-3018	AirSep Assy, 1/4" Drain
W-3018-B	AirSep Assy, 3/8" Drain
W-3019	AirSep Assy, 1/4" Drain
W-3019-B	AirSep Assy, 3/8" Drain
W-3020	AirSep Assy, 1/4" Drain
W-3020-B	AirSep Assy, 3/8" Drain
W-3024	AirSep Assy, 1/4" Drain
W-3024-B	AirSep Assy, 3/8" Drain
W-3025	AirSep Assy, 1/4" Drain
W-3027	AirSep Assy, 1/4" Drain
W-3028	AirSep Assy, 1/4" Drain
W-3029	AirSep Assy, 1/4" Drain
W-3030	AirSep Assy, 1/4" Drain
W-3031	AirSep Assy, 1/4" Drain
W-3032	AirSep Assy, 1/4" Drain

**MiniSeps for Engine Breathers**

<u>P/N</u>	<u>DESCRIPTION</u>
W-4000-A	MiniSep Assy, 1" Inlet
W-4000-B	MiniSep Assy, 3/4" Inlet
W-4000-C	MiniSep Assy, 5/8" Inlet

**MiniSeps for Wet Vacuum Pumps**

<u>P/N</u>	<u>DESCRIPTION</u>
W-4100-A	MiniSep Assy, 1" Inlet
W-4100-B	MiniSep Assy, 3/4" Inlet
W-4100-C	MiniSep Assy, 5/8" Inlet

**Applicability:** TYPICAL MINISEP™ PARTS REQUIRED TO INSTALL  
ON AIRCRAFT ENGINE BREATHER LINE OR  
WET VACUUM PUMPS

**Drawing:** AFC-W360  
**Revision:** C  
**Date:** 08/24/06

MiniSep™ Parts List

<u>Index</u>	<u>Part Number</u>	<u>Description</u>	<u>Used With Minisep</u>	<u>Quantity</u>
01a.	W-4000-A	MiniSep Assy, 1" Inlet - For Engine Breather		(1)
01b.	W-4000-B	MiniSep Assy, 3/4" Inlet - For Engine Breather		(1)
01c.	W-4000-C	MiniSep Assy, 5/8" Inlet - For Engine Breather		(1)
02a.	W-4100-A	MiniSep Assy, 1" Inlet - For Wet Vacuum Pumps		(1)
02b.	W-4100-B	MiniSep Assy, 3/4" Inlet - For Wet Vacuum Pumps		(1)
02c.	W-4100-C	MiniSep Assy, 5/8" Inlet - For Wet Vacuum Pumps		(1)
03.	AN912-3D	3/8" - 1/8 NPT Reducer Bushing	ALL	(1)
04.	AN914-1D	90° Fitting, 1/8" Elbow	ALL	(1)
05.	AN840-4D	Straight Fitting, 1/8" Hose Nipple	ALL	(1)
06a.	Hose-1/4	Airwolf 1/4" I.D. Hose	ALL	(24)
06b.	Hose-1"	Airwolf 1" I.D. Hose	W-4000-A & W-4100-A	(18)
06c.	Hose-3/4	Airwolf 3/4" I.D. Hose	W-4000-B & W-4100-B	(18)
06d.	Hose-5/8"	Airwolf 5/8" I.D. Hose	W-4000-C & W-4100-C	(18)
07a.	MM-4	1/4" I.D. Hose Clamp	ALL	(2)
07b.	QS100M16H	1" I.D. Hose Clamp	W-4000-A & W-4100-A	(2)
07c.	QS100M12H	3/4" I.D. Hose Clamp	W-4000-B & W-4100-B	(2)
07d.	QS100M10H	5/8" I.D. Hose Clamp	W-4000-C & W-4100-C	(2)
07e.	QS100M10H	5/8" I.D. Hose Clamp	ALL	(1)
08a.	MS21919WDG-14	7/8" I.D. Adel Clamp	ALL	(1)
08b.	MS21919DG-48	3" I.D. Adel Clamp	ALL	(1)
09.	SCAT-3	3/4" I.D. Duct	ALL	(18")
10.	AN525-10R10	#10 Screw, 5/8" Long	ALL	(2)
11.	AN960-10	#10 Washer	ALL	(4)
12.	MS20365-1032A	#10 Locknut	ALL	(2)

AIRWOLF AIRSEP INSTRUCTIONS FOR CONTINUED AIRWORTHINESS (ICA)

A/C Make : \_\_\_\_\_ Model: \_\_\_\_\_

Serial#: \_\_\_\_\_ N#: \_\_\_\_\_



This Instructions for Continued Airworthiness (ICA) meets the requirements of 14 CFR Part 23 Appendix G.

AIRWORTHINESS LIMITATIONS

- 1.0 The Airworthiness Limitations Section is FAA approved and specifies maintenance required under 43.16 and 91.403 of the Federal Aviation Regulations unless an alternate program has been FAA approved.
- 2.0 An STC incorporated in a larger field approval major alteration may have an airworthiness limitation. The FAA inspector should not establish, alter, or cancel an airwothiness limitation without coordinating with the appropriate FAA Type Certificate Holding Office.

SECTION	DESCRIPTION
1.	Introduction: The Airwolf AirSep system is a passive oil recovery system. There are no moving parts within the AirSep.
2.	Description: The AirSep is a device through which the process of coalescence, allows the oil that is normally expelled out the engine breather tube into the atmosphere, to be collected within the device for recovery at which time it is then returned back into the engine for reuse.
3.	Servicing information: N/A
4.	Maintenance Instructions: Clean inside of AirSep and oil return line to engine with Stoddard Solvent, Mineral Spirits or other suitable solvent, at each annual or 100 hr. inspection. In the event of a vacuum pump failure, disassemble Air/Oil Separator, thoroughly clean it and all lines, hoses and fittings and remove any traces of vacuum pump debris. Reassemble and lightly torque top nut only enough to prevent top and bottom can from rotating and center gasket to seal to prevent any leakage.
5.	Trouble shooting information: If any oil is seeping out of center seam of AirSep can, replace center gasket and lightly torque top nut only enough to prevent further leakage which in most cases is 12 in/lb. If breather oil is found on the belly of the aircraft, check that outlet duct is located as per the above installation instructions and is not located in or near the high velocity airstream.
6.	Removal and replacement information: Refer to the above Approved Installation Instructions for the AirSep kit.
7.	Diagrams: N/A
8.	Special inspection requirements: None
9.	Application of protective treatments: N/A
10.	List of special tools: N/A
11.	Recommended overhaul periods: N/A
12.	Revision: The latest revision of this ICA can be found at <a href="http://www.airwolf.com">www.airwolf.com</a>

MASTER DRAWING LIST

Drawing: MDL-W100

Revision: C

Date: 08/24/06

DESCRIPTION	PART#	Rev	Date	DESCRIPTION	PART#	Rev	Date-
CAN TOP	W-2000	D	3/14/00	FLANGE	W-2043	A	3/10/03
CAN BOTTOM	W-2001	D	3/14/00	FLANGE	W-2043-1	A	3/10/03
INNER CONE	W-2002	A	10/1/01	DOUBLER	W-2045	C	10/1/01
GASKET	W-2003	D	9/5/97	AIRSYPHON PUMP	W-2046	D	11/1/78
BUSHING	W-2004	G	5/11/78	AIRSYPHON PUMP	W-2046-1	D	11/1/78
AIR SYPHON PUMP	W-2008	K	8/26/77	AIRSYPHON PUMP	W-2046-2	A	8/1/02
STANDPIPE	W-2009.1	E	9/16/93	AIRSYPHON PUMP	W-2046-3		11/19/04
TEE BOLT	W-2009.2	C	3/16/97	AIRSYPHON PUMP	W-2046-4		3/10/05
STEEL FILAMENT	W-2010	E	9/5/77	DOUBLER	W-2047	A	3/1/05
BRACKET	W-2011	A	10/1/01	DOUBLER	W-2048	A	3/1/05
DOUBLER	W-2012	D	10/1/01	CAN TOP	W-2050	G	3/14/00
DUCT BRACKET	W-2013		5/26/05	CAN TOP	W-2050L	E	5/18/78
AIRSYPHON PUMP	W-2014	A	4/1/02	AIRSEP BOTTOM	W-2051	J	3/14/00
GRID	W-2017	D	10/1/01	CAN TOP	W-2052R	E	2/24/78
1/2" OD AIR-TEE	W-2018	J	9/16/77	CAN TOP	W-2053R	E	10/1/78
5/8 OD AIR-TEE	W-2018-1	A	6/1/03	CAN TOP	W-2054R	E	6/12/80
DOUBLER	W-2021	D	9/22/77	CAN TOP	W-2055	C	10/1/01
AIR-TEE	W-2022	E	11/19/77	CAN TOP	W-2056	C	5/1/02
AIR-TEE	W-2022-1	A	8/1/02	CAN TOP	W-2057	B	4/1/02
DOUBLER	W-2023	E	12/9/77	CAN TOP	W-2058	C	4/1/02
FLANGE	W-2024	D	12/9/77	CAN TOP	W-2059	B	4/1/02
BREATHER TUBE	W-2025-1	D	12/8/77	CAN TOP	W-2060	B	4/1/02
BREATHER TUBE	W-2025-2	D	12/8/77	CAN TOP	W-2062	B	6/1/02
DOUBLER	W-2027	D	2/2/78	CAN TOP	W-2070	A	6/1/02
BREATHER TUBE	W-2028-1	E	2/6/78	CAN TOP	W-2071	A	8/1/02
BREATHER TUBE	W-2028-2	E	2/6/78	CAN TOP	W-2072	A	8/1/02
BREATHER TUBE	W-2028-3	D	2/6/78	CAN TOP	W-2073	B	8/1/02
BRACKET	W-2029	C	9/20/78	CAN TOP	W-2074	B	10/1/02
BRACKET	W-2029-1	A	9/28/03	CAN TOP	W-2075	A	10/1/02
BREATHER TUBE	W-2030	E	4/26/78	CAN TOP	W-2076	B	10/1/02
AIRSYPHON PUMP	W-2031	H	4/24/78	CAN TOP	W-2077	B	4/1/03
BREATHER TUBE	W-2032	D	6/30/78	CAN TOP	W-2078	B	7/1/03
BRACE	W-2033	C	6/27/95	CAN TOP	W-2079	B	10/1/02
BREATHER TUBE	W-2034	D	9/20/78	CAN TOP	W-2080	A	10/1/02
BREATHER TUBE	W-2034-1	A	6/1/02	CAN TOP	W-2081	B	1/19/06
BREATHER TUBE	W-2034-2	A	8/1/02	CAN TOP	W-2082		1/19/06
BREATHER TUBE	W-2034-3		1/21/06	CAN TOP	W-2083		1/19/06
BREATHER TUBE	W-2035	D	9/20/78	CAN TOP	W-2084		3/28/06
BREATHER TUBE	W-2035-1	A	4/1/02	CAN TOP	W-2085		3/28/06
BRACE	W-2036	B	7/21/78	C CHANNEL	W-2100	B	9/15/64
BRACKET	W-2037	B	7/21/78	DOUBLER	W-2150	A	10/1/01
TEE	W-2038	C	6/1/03	BRACKET	W-2151	A	4/1/02
BRACE	W-2039	B	10/13/78	AIR TEE	W-2152	A	4/1/03
AIRSYPHON PUMP	W-2040	B	10/2/78	AIRSYPHON PUMP	W-2153		7/8/06
BRACE	W-2041	C	9/20/78	SHROUD TUBE	W-2154-1	A	4/1/03
DOUBLER	W-2042	A	10/1/01	SHROUD TUBE	W-2154-2	A	4/1/03

MASTER DRAWING LIST

Drawing: MDL-W100

Revision: C

Date: 08/24/06

DESCRIPTION	PART#	Rev	Date
SHROUD TUBE	W-2154-3	A	4/1/03
SHROUD TUBE	W-2154-4	A	4/1/03
SHROUD TUBE	W-2154-5	A	2/20/06
SHROUD TUBE	W-2154-7	A	4/1/03
SHROUD TUBE	W-2155-1	A	4/1/03
SHROUD TUBE	W-2155-2	A	4/1/03
ROCKER BOX MOD	W-2157	A	4/1/03
SPRING	W-2160	A	3/14/00
AIRSEP	W-3000		3/14/00
AIRSEP	W-3001	A	10/1/01
AIRSEP	W-3002	A	10/1/01
AIRSEP	W-3002-B	A	10/1/01
AIRSEP	W-3003	A	10/1/01
AIRSEP	W-3004		4/1/02
AIRSEP	W-3009	A	10/1/01
AIRSEP	W-3010		10/1/01
AIRSEP	W-3011	A	10/1/01
AIRSEP	W-3011-B	A	10/1/01
AIRSEP	W-3012		4/1/02
AIRSEP	W-3014	A	4/1/02
AIRSEP	W-3014-B	A	4/1/02
AIRSEP	W-3015	A	4/1/02
AIRSEP	W-3016		4/1/02
AIRSEP	W-3017	A	4/1/02
AIRSEP	W-3018	A	8/1/02
AIRSEP	W-3018-B	A	8/1/02
AIRSEP	W-3019	A	8/1/02
AIRSEP	W-3019-B	A	8/1/02
AIRSEP	W-3020	A	8/1/02
AIRSEP	W-3020-B	A	8/1/02
AIRSEP	W-3022	A	8/1/02
AIRSEP	W-3023		8/1/02
AIRSEP	W-3024	A	8/1/02
AIRSEP	W-3024-B	A	8/1/02
AIRSEP	W-3025		1/2/06
AIRSEP	W-3027		1/2/06
AIRSEP	W-3029		1/2/06
AIRSEP	W-3030		1/2/06
AIRSEP	W-3031		1/2/06
AIRSEP	W-3032		1/2/06
MINISEP ASSY	W-4000-A		3/17/05
MINISEP ASSY	W-4000-B		3/17/05
MINISEP ASSY	W-4000-C		3/17/05
SMALL CAN BOTTOM	W-4010		3/17/05
AIRSEP BOTTOM	W-4015		3/17/05
SMALL CAN TOP	W-4020		3/17/05

DESCRIPTION	PART#	Rev	Date
MINI CAN TOP ASSY	W-4022		3/17/05
MINI CAN TOP ASSY	W-4024		3/17/05
MINI CAN TOP ASSY	W-4026		3/17/05
INNER CONE	W-4030		3/17/05
STANDPIPE	W-4035		3/17/05
SPRING	W-4040		3/15/05
GRID	W-4045	A	3/17/05
SOC HD CAP SCR	W-4055		3/17/05
1/4" HOSE BARB	W-4070		11/15/05
MINISEP FITTING	W-4080		9/20/05
MINISEP ASSY	W-4100-A		3/17/05
MINISEP ASSY	W-4100-B		3/17/05
MINISEP ASSY	W-4100-C		3/17/05
HALF COUPLING	W-4042		3/17/05